

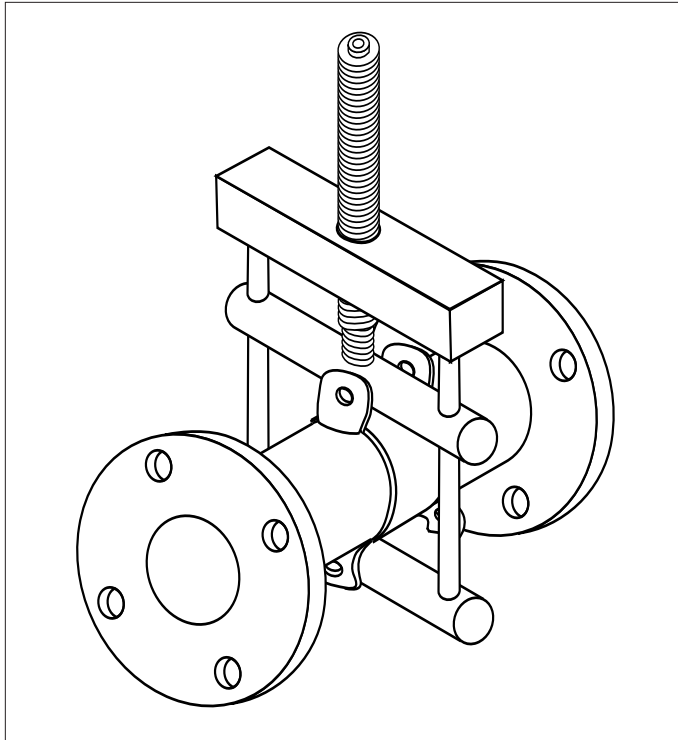

## Valve Technical Information

# Positive Opening Tabs



Red Valve Company, Inc., offers Positive Opening Tabs as an option for Series 70, 75 and 80 Manual Pinch Valves. This feature is standard on Red Valve Series 5200, 5400 and 5800 Control Pinch Valve products.

Positive Opening Tabs are used to ensure, mechanically, that Red Valve pinch valve sleeves return to a full round configuration. This is especially important for valves in low-pressure service (less than 2 psi) and essential in vacuum applications.

The Positive Opening Tabs are attached to the exterior of the sleeve and are secured by a Nylon-reinforced “Belly Band” around the outside of the POTs and the outside of the sleeve body. This achieves two major operational advantages. First, the pinch bar pull on the tabs does not stress the internal structure of the sleeves, and no interior damage can result and long sleeve life potential is maintained.

Secondly, as the “Belly Band” is pulled from the top and bottom, the sides are drawn toward the centerline of the valve. This mechanically assists the sleeve externally, in addition to the line pressure inside the sleeve, to return the sides of the sleeve to a completely round position. Thus structural stress on the sleeve is minimized and superior performance is enhanced.

The “break-in” period of pinch valve sleeves varies with the line pressures and the nature of the applications. However, in no way does the break-in period affect the performance or wear of the sleeve. Where larger size particles may be passing through the valve, Positive Opening Tabs can improve the flow efficiency of the system dramatically.

