

Series G Large Diameter

- ▶ Robust construction
- ▶ Low-profile design
- ▶ Low operating torque
- ▶ Custom fabrication available



Red Valve manufactures the Series G in line sizes up to 144 inches for large-diameter pipeline installations. Large Series G valves are constructed similarly to smaller valves but feature a fabricated carbon steel body as opposed to cast iron. All wetted parts of the valve are still stainless steel, but they can be constructed of 304, 316 or 316L material. Large Series G valves benefit from Red Valve's vast experience in large-diameter pipeline products and feature a robust construction designed to handle the immense forces involved in large-diameter pipelines.

The Series G is available with a bevel-gear manual operator or electric motor actuator. Due to the size of the valve, electric operation is normally preferable. Large Series G valves are used in a variety of applications, ranging from pumping stations and flood control to mining and power generation.

Please specify working pressure as construction will vary.

Materials of Construction

- ▶ Fabricated carbon steel body
- ▶ Lined with either 304, 316 or 316L
- ▶ 316 metal or EPDM resilient seats
- ▶ Manual bevel gear, electric or hydraulic actuator
- ▶ ANSI class 150

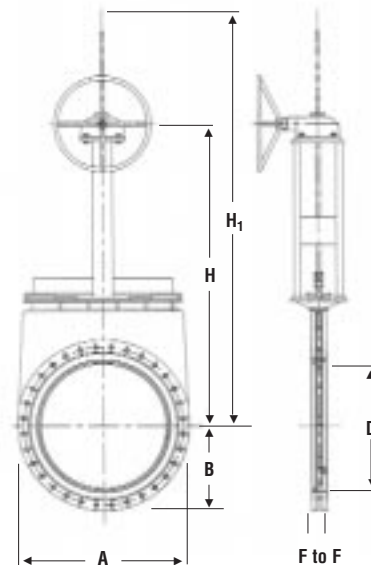

Valve Size D	Length F to F	Width A	Height B	Height Closed H	Height Open H ₁	Stem Diameter	Gate Thickness	Maximum Working Pressure psi
30"	6"	38 3/4"	19 3/8"	75"	111"	2 3/4"	Gate thickness varies per pressure requirement.	Engineered per application from 25-150 psi
36"	7"	46"	23"	90"	132"	3 1/2"		
42"	7"	53"	26 1/2"	105"	153"	3"		
48"	7 1/2"	59 1/2"	29 3/4"	120"	174"	3 1/2"		
54"	9"	66 1/4"	33 1/4"	135"	195"	3 1/2"		
60"	9"	73"	36 1/2"	150"	216"	3 1/2"		
66"	9"	80"	40"	165"	237"	4"		
72"	9 1/4"	86 1/2"	43 1/4"	180"	258"	4"		

For sizes to 144 inches, contact factory.