

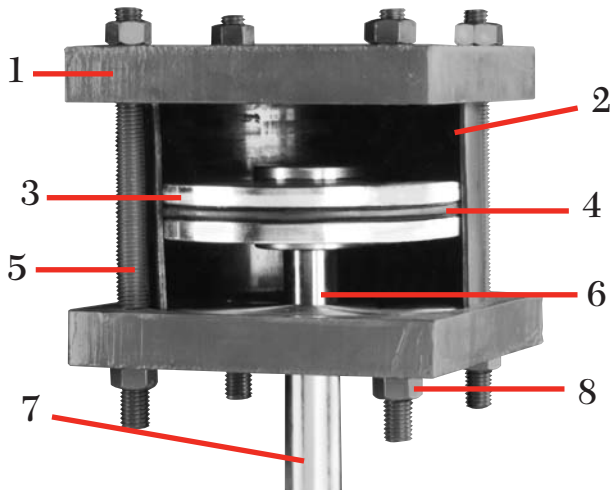

Actuator Technical Information

Pneumatic Actuators

Red Valve Actuators are manufactured with lightweight composite tubing, which is fiberglass-reinforced epoxy. The actuator material is impregnated with an anti-friction additive to reduce the piston and O-ring to cylinder friction. The actuator is self-lubricating, and the inside of the cylinder is honed to a 5-15 micro inch finish. The combination of the surface finish and the self-lubricating feature greatly increase O-ring life.



1	Cylinder Head	5	Threaded Rods
2	Cylinder Tube	6	Wiper Ring
3	Piston	7	Piston Rod
4	O-Ring Seal	8	Fastening Nuts

The composite is resistant to chemical attack and corrosion, making it ideal for most environments. It has an impact strength of 40 izod ft-lbs, which makes the actuator much more dent-resistant than aluminum or brass.

Red Valve Actuators have a maximum operating pressure of 150 psig and can withstand external operating temperatures of -90°F to 225°F.

Piston rods are made of polished 304 stainless steel, and the piston rod is sealed with a polyurethane lip seal. Both the piston rod and seal are protected by a wiper ring which cleans the piston rod before it passes through the lip seal. The rod seal and wiper ring are held in place by a bronze stem bushing, which prevents galling of the piston rod. The combination of a stainless steel piston rod, wiper ring, and lip seal contribute to extended actuator life.

Double Acting Actuator

ATO/ATC R style actuators are used on Series 5200, 5200 D-Port, and 5300 Open Frame Control Valves, and Series G and Flexgate Knife Gate Valves. These actuators use air to open and close the valve.

Single Acting Actuator

ATO/FCS and ATC/FOS RS style actuators consist of either a fail close spring which is preloaded to provide enough force to close and seal the sleeve (or gate) upon air loss, or a fail-open spring which drives the valve open upon air loss. Fail-open spring actuators are used primarily in low pressure or partial vacuum services, where the line pressure alone is not sufficient to fully open the valve, and on fail-open knife gate applications. The RS type actuator can be used on the same valves as the R style actuator.

Materials of Construction

Cylinder HeadsT6061 Aluminum
Cylinder TubeBlack Amalga
PistonT6061 Aluminum
O-Ring SealNeoprene
Threaded RodsSAE Grade 5 Carbon Steel
Wiper RingPolypak, Buna-N
Piston Rod304 Stainless Steel
Fastening NutsStainless Steel
Mounting PadAISI 1018 Carbon Steel
Retaining PlateAISI 1018 Carbon Steel

RS Type Actuators

