

Series 5300 Open Frame

- ▶ Cost-effective, open-frame control valve design
- ▶ Lightweight
- ▶ High cycle life, repeatable control
- ▶ Sleeve is the only wetted part
- ▶ No packing to maintain, ever



Materials of Construction

- ▶ Carbon steel frame; stainless steel optional
- ▶ Sleeves available in Pure Gum Rubber, Neoprene, Hypalon®, Chlorobutyl, Buna-N, EPDM and Viton®
- ▶ Pneumatic, hydraulic or electric actuators
- ▶ Drilled and tapped to mate with ANSI B16.5 Class 150 Flanges; DIN, ASA or BS standards optional

The Series 5300 features many of the same advantages of the Series 5200 in a lightweight, low-cost, open-frame design. The open-frame design is possible because the sleeve is the only wetted part of the Pinch Valve, protecting the operating mechanism and frame from corrosive or abrasive attack from the line process. A heavy-duty, rugged pinch mechanism pinches the sleeve, resulting in accurate flow control. The Series 5300 has no packing to maintain or seats to wear and is well suited for handling corrosives, powders and slurry materials.

Pneumatic, electric or hydraulic actuators are available, complete with pneumatic or electropneumatic positioners. The Series 5300 Control Pinch Valve is designed with a stroke adjustment that is located inside the valve yoke in valve sizes up to 6". The stroke adjustment unit allows customers to easily make small control changes in the field and simplifies actuator maintenance by creating a removal point in the valve stem. Particularly in slurry applications, the stroke adjustment unit allows for fine-tuned flow control as the sleeve wears. Due to the fabricated open-frame design of the Series 5300, slight variations in face-to-face length can be accommodated.

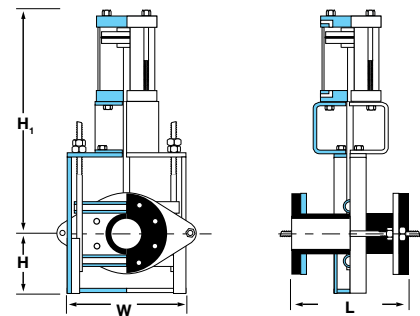

Dimensions Series 5300 Open-Frame Control Valve

VALVE SIZE	LENGTH L	WIDTH W	HEIGHT		WORKING PRESSURE psi	WEIGHT ATO/ATC lbs*
			H	ATO/ATC [*]		
2"	10"	8"	3-1/2"	22"	150	63
2-1/2"	10-7/8"	9"	4"	24"	150	75
3"	11-3/4"	11-1/2"	4-1/4"	26"	150	93
4"	13-7/8"	13-1/2"	6-5/8"	29"	150	113
6"	17-3/4"	16-7/8"	7-5/8"	36"	150	153
8"	24"	19-7/8"	9-1/8"	43"	125	198
10"	30"	23-1/2"	11"	43"	100	260
12"	36"	27-1/2"	11-13/16"	46"	100	355
14"	42"	31"	14"	51"	75	600
16"	48"	34"	15"	56"	50	800
18"	54"	44"	16-1/2"	59"	50	1,000
20"	60"	40"	17"	62"	50	1,225
24"	72"	52"	23"	81-1/2"	50	2,100
30"	90"	74"	30"	102"	50	4,100
36"	108"	84"	36"	122"	45	7,100

*Consult factory for specific heights and weights of Fail-Close or Fail-Open valves. For larger sizes up to 72", consult factory.