

# Application Data

Chemical ♦ Latex ♦ Control Valves

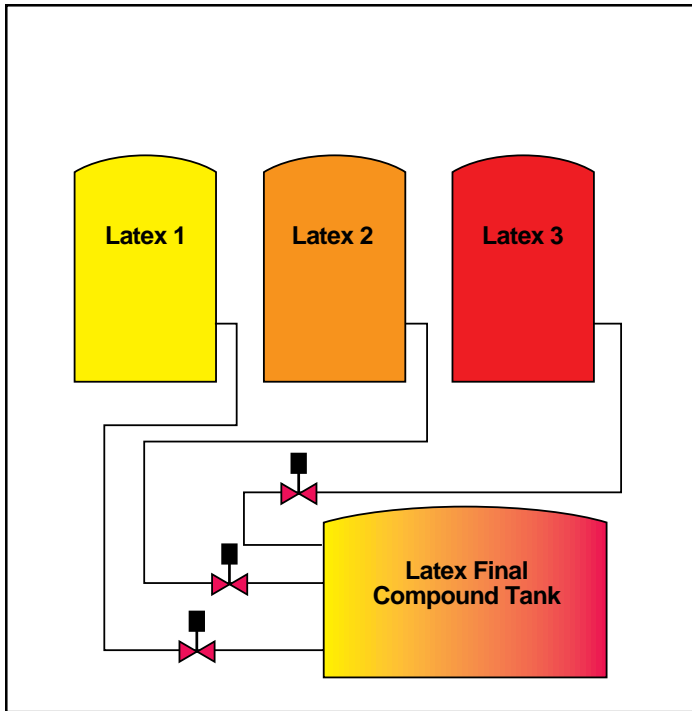

A chemical manufacturer needed to mix 3 different latex fluids into one compound that would eventually be used as a backing for carpeting. It was important to maintain the correct ratio of the the three compounds, so precice a control valve was needed.

The latex material however was extremely sticky, and tended to clog traditional valve styles. The manufacturer needed a control valve that would not clog, and be able to accurately control the latex flowing at 175 gpm at 50 psi.

The Red Valve Series 5200 Control Valve was chosen with a 3" x 2" Cone Sleeve and pneumatic actuator. The high turndown ration of the Cone Sleeve allowed a pressure drop to 40 psi while maintaining a smooth, laminar flow. The flexing action of the sleeve prevented buildup inside the valve and prevented clogging.

