



SERIES 2600 / 2633 Miniflex

Installation, Operation, and Maintenance Manual



Red Valve's Series 2600 pinch valve and Series 2633 small diameter inline check valve are the simplest valves available to industry. They have only four parts and require little or no maintenance. These valves are designed with threaded end connections for easy installation and removal on small lines up to 3" in diameter. A spare replacement sleeve should be ordered when the valve is placed in service.

NOTE: 2" and 3" PVC Series 2600's may have hose clamps on the body of the valve. These clamps must be loosened when removing the sleeve.

IMPORTANT

Please take a moment to review this manual. Before performing any maintenance on the valve be sure that the pipeline has been depressurized. The improper installation or use of this product may result in personal injury, product failure, or reduced product life. Red Valve Company can accept NO liability resulting from the improper use or installation of this product. If you have any questions or problems, please call the customer service hotline at (412) 279-0044. We appreciate your comments. Thank you for choosing Red Valve.

INSPECTION OF PRODUCT

Before installing, be sure the pipe threads are clean. A sealing material such as pipe dope can be used. Direction of flow is indicated on the 2633. Be sure that it is in the proper orientation before installing.

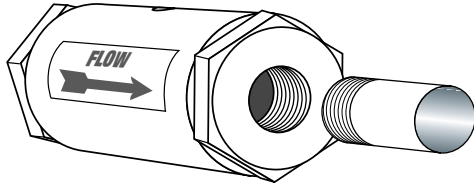

INSTALLATION

1. INSTALLING VALVE

Use a wrench to tighten the valve by turning the end caps. Turning the body can damage the rubber inside. Once installed, if a small gap exists between the body and end cap, do not tighten further. This can twist the rubber flange inside and cause damage.

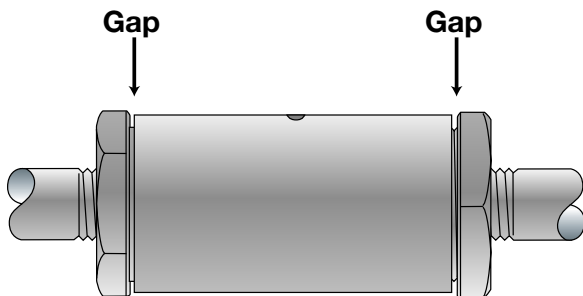

2. AIR SUPPLY PORT

Air supply is connected to the 1/4" NPT port. This port is normally plugged on the 2633, but can be used as a drain or piped as a flush port. Use the chart below to determine the correct air pressure needed to close the 2600.

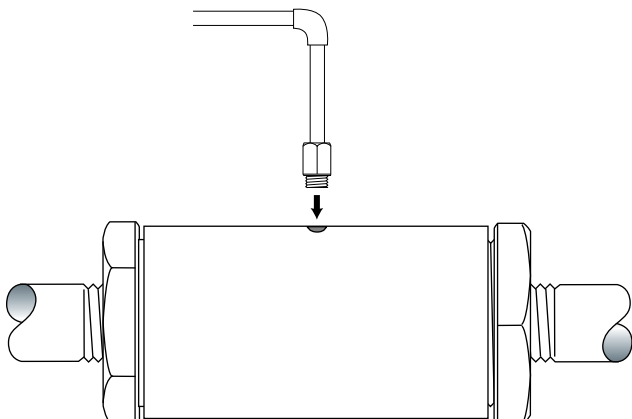

AIR CLOSING PRESSURE

Valve Size (in.)	Internal Line Pressure (psi)	Air Closing Pressure PGR (psi)	Air Closing Pressure Synthetic (psi)
1/8" — 1/2"	75	29	35
3/4" — 1"	75	31	39
1-1/4"	50	31	39
1-1/2" — 2"	50	37	44

* Note: Closing pressures are to be added to line pressure.

3. PRESSURE REGULATORS

To avoid over-pressurizing the valve when closing, a pressure regulator should be installed. Pressure in excess of 50 psi above pipeline pressure can tear the rubber at the flange. Higher pressures require the sleeves to be reinforced with fiberglass short threads.

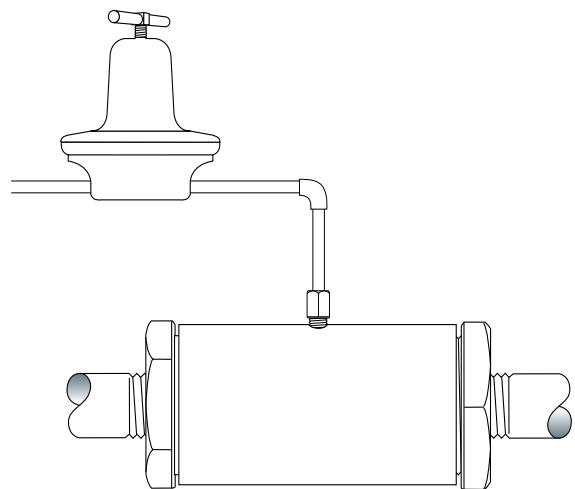

REPLACING SLEEVES

1. REMOVE VALVE

Remove the valve from the pipeline using a wrench to turn the end caps. Do not grip the valve body! A spare replacement sleeve should be placed on order when this valve is placed in service.

2. REMOVE SLEEVE

2600: Unscrew both end caps from the body. Pry one side of either rubber flange out of its seat with a dull blade or screwdriver. Fold this edge over into the center of the sleeve and push the flange fully through the seat. Pull the sleeve out of the body.

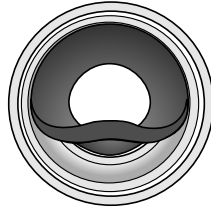

2633: Unscrew the end cap on the inlet side of the valve. Pry one side of the rubber flange up using a screwdriver or dull blade and pull up to remove the duckbill sleeve from the valve body. The other rubber seal will only need to be changed if seriously worn.

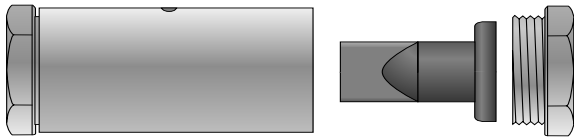

3. REPLACE SLEEVE

2600: Lubricate the new sleeve with soapy water. Pinch the sides of one flange together and squeeze through the seat. Push the sleeve through the valve body. Carefully pull the flange through the opposite seat. Do not use sharp tools or screwdrivers.

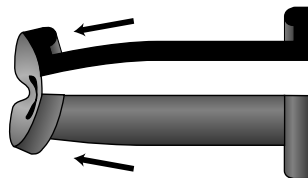

The ridge molded into the rubber flange must be pressed into the groove in the seat. Use a dull blade to pry up one edge of the flange and snap the flange into place. Firmly push into place around the entire flange.

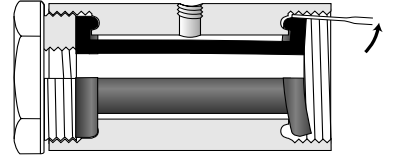

2633: The new duckbill sleeve is simply inserted into the body. Make sure that the ridge on the rubber flange properly fits into the groove in the seat by firmly pressing into place around the entire flange.

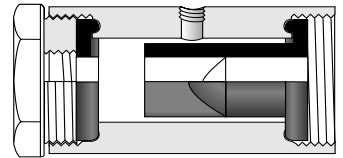

4. REINSTALL END CAPS

To reinstall the end caps, lubricate the exposed rubber flange and tighten the end cap until snug. Do not over-tighten or the rubber flange may twist or tear. Caps will not bottom out on the valve body.

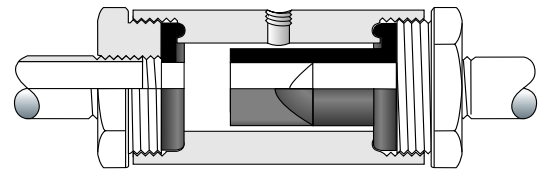

RED VALVE WARRANTY

WARRANTIES - REMEDIES - DISCLAIMERS - LIMITATION OF LIABILITY

Unless otherwise agreed to in writing signed by Red Valve, all Products supplied by Red Valve will be described in the specifications set forth on the face hereof.

THE WARRANTIES SET FORTH IN THIS PROVISION ARE EXCLUSIVE AND IN LIEU OF ALL OTHER WARRANTIES WHETHER STATUTORY, EXPRESS OR IMPLIED (INCLUDING ALL WARRANTIES OF MERCHANTABILITY AND FITNESS FOR A PARTICULAR PURPOSE AND ALL WARRANTIES ARISING FROM COURSE OF DEALING OR USAGE OR TRADE).

Red Valve Products are guaranteed for a period of one year from date of shipment, against defective workmanship and material only, when properly installed, operated and serviced in accordance with Red Valve's recommendations. Replacement for items of Red Valve's manufacture will be made free of charge if proved to be defective within such year; but not claim for transportation, labor or consequential damages shall be allowed. We shall have the option of requiring the return of the defective product to our factory, with transportation charges prepaid, to establish the claim and our liability shall be limited to the repair or replacement of the defective product, F.O.B. our factory. Red Valve will not assume costs incurred to remove or install defective products nor shall we incur backcharges or liquidated damages as a result of warranty work. Red Valve does not guarantee resistance to corrosion erosion, abrasion or other sources of failure, nor does Red Valve guarantee a minimum length of service, or that the product shall be fit for any particular service. Failure of purchaser to give prompt written notice of any alleged defect under this guarantee forthwith upon its discovery, or use, and possession thereof after an attempt has been made and completed to remedy defects therein, or failure to return product or part for replacement as herein provided, or failure to install and operate said products and parts according to instructions furnished by Red Valve, or failure to pay entire contract price when due, shall be a waiver by purchaser of all rights under these representations. All orders accepted shall be deemed accepted subject to this warranty which shall be exclusive of any other or previous warranty, and shall be the only effective guarantee or warranty binding on Red Valve, anything on the contrary contained in purchaser's order, or represented by any agent or employee of Red Valve in writing or otherwise, not withstanding implied warranties. RED VALVE MAKES NO WARRANTY THAT THE PRODUCTS, AUXILIARIES AND PARTS ARE MERCHANTABILITY OR FIT FOR ANY PARTICULAR PURPOSE.



SERIES 2600 2633 IOM 5/18