

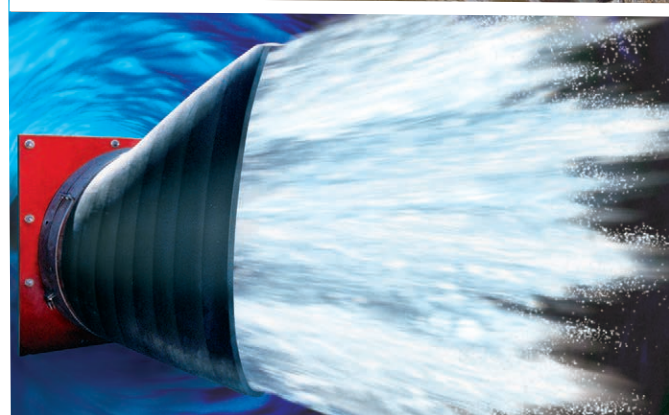

Red Valve

The Tideflex[®] Duckbill Check Valve
Advantage: Ahead of the Curve!



A Pioneer in the Check Valve Industry

In 1984, the United States Environmental Protection Agency (EPA) commissioned Red Valve to develop and test an alternative to flap gate valves. In their report, *Development and Evaluation of a Rubber "Duck Bill" Tide Gate*, the EPA states, "Increasing the reliability and performance of tide gates has a beneficial impact on the general pollution abatement program for the nation's waterways."

The EPA rigorously tested the Tideflex® Duckbill Check Valve for two years and found that the valve showed "Significant improvement over flap gate valves in terms of leakage inflow, entrapment of debris, capability to self clean and susceptibility to marine fouling."

Richard Field, United States EPA, stated the following in regard to the development of the Tideflex® Check Valve:

"Tide water intrusion is costing the United States multi-millions of dollars because it is water that really doesn't have to be treated that intrudes into the sewer system and treatment plants. In the long run, there will be a lot of money saved for the minor investment that we made here."

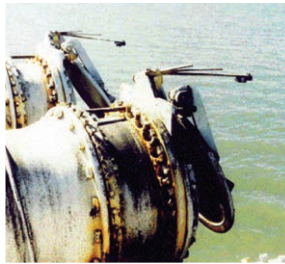

Problem



Solution

In response, the elastomer Tideflex® Duckbill Check Valve was developed to eliminate the operational and maintenance problems associated with flap gate check valves, including corrosion of mechanical parts, freezing open or shut, warping, and clogging due to entrapped debris.

Since its creation, years of research, development, testing and performance combine to make the Tideflex® Duckbill Check Valve today's most reliable valve for backflow prevention. Currently, more than 600,000 Tideflex® Check Valves are solving inflow and intrusion problems around the world.

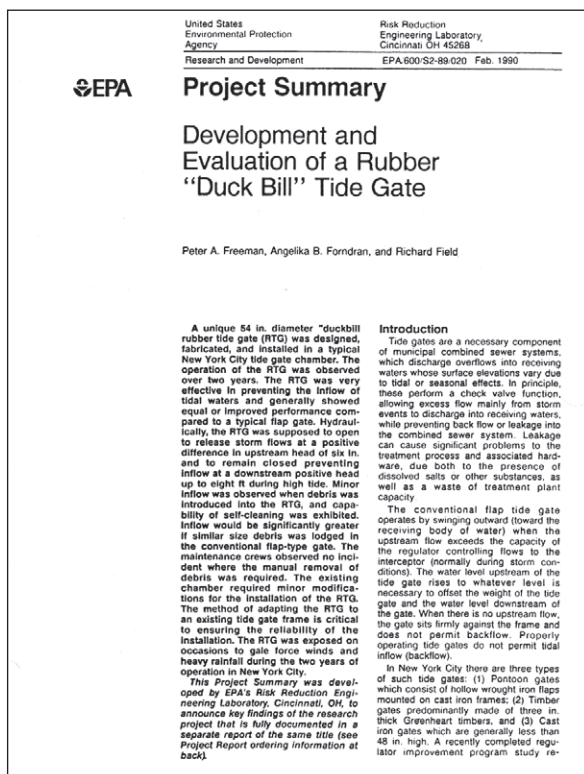

The EPA report, stating the benefits of Tideflex® Check Valves.

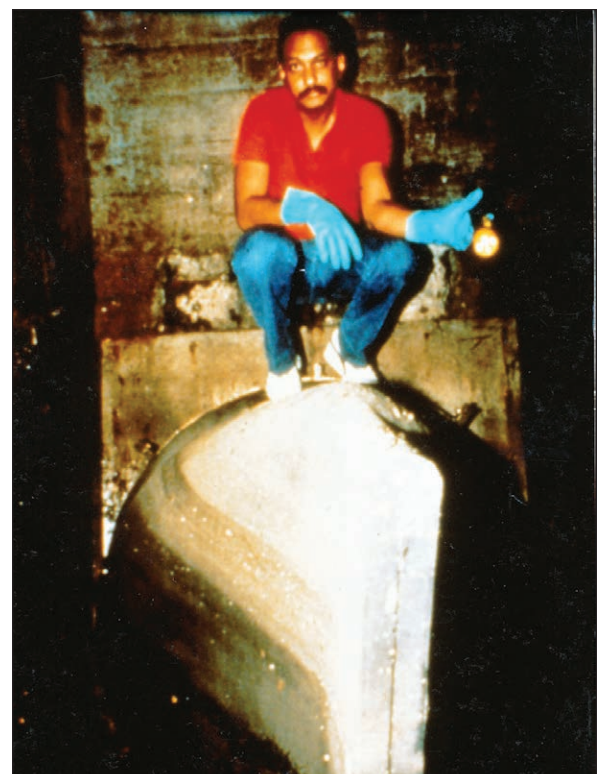

The original 54" Tideflex® Duckbill Check Valve in New York City, New York.

The Tideflex® Advantage

The Tideflex® Duckbill Check Valve is a revolutionary design for backflow prevention. Our check valves offer low cracking pressure to eliminate standing water. They also have low head loss and are not affected by rust, corrosion or lack of lubrication.

Tideflex® Check Valves are cost-effective because they require no maintenance or repairs and have a long life span. The valves operate using line pressure and backpressure to open and close, so no outside energy source is required. Tideflex® Check Valves make excellent replacements for ineffective metal flap gate valves because they have no moving parts that can corrode, warp or freeze.

Tideflex® Duckbill Check Valves have years of proven field operation, research, development and continued engineering enhancements that make them the most reliable in the industry today. Our check valves achieve the tightest possible seal for backflow applications, particularly at low flow rates.

Tideflex® Check Valves have numerous technical differences from check valves made by other manufacturers. The Tideflex® Advantage ensures that you receive a superior check valve through:

- Rigorous EPA Testing
- Independent Hydraulic Testing
- In-House Testing
- Finite Element Analysis (FEA)
- Hydraulic Variations
- Curved Bill Design
- Stronger Structure
- Increased Bill Height
- Increase in Flow Capacity
- Eccentric Flat-Bottom Design

Principle of Operation:

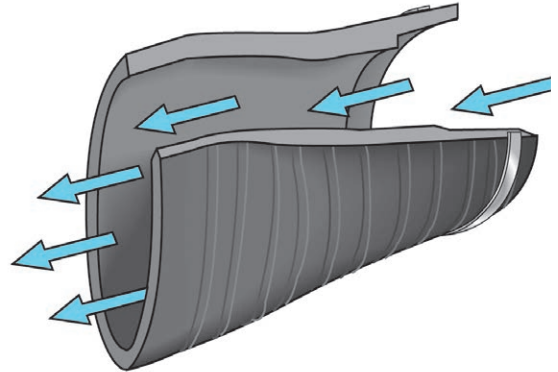

The Tideflex® Check Valve opens with positive pressure.

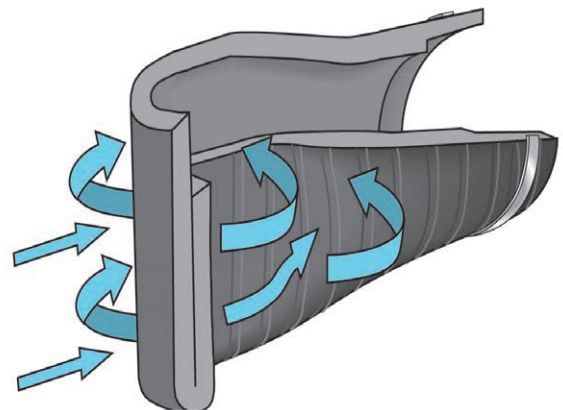

Reverse pressure seals the Curved Bill of the Tideflex® Check Valve to prevent backflow.

Engineered Features:

- No Moving or Mechanical Parts
- 100% Elastomer Construction
- Low Head Loss
- Sensitive Enough to Open with as Little as 1" of Water Pressure
- Custom-Built to Your Flow Specifications
- Cost-Effective, Reliable Replacement for Traditional Flap Gate Valves
- Silent, Non-Slamming
- Self-Draining, Eliminates Standing Water

Independent Hydraulic Testing

Tideflex® Duckbill Check Valves have undergone extensive independent hydraulic testing since the 1980s. Comprehensive testing generated a massive amount of data, which was analyzed to model the effect of valve geometry and relative stiffness on valve hydraulic performance.

Check Valves were tested from 2-48" in numerous hydraulic variations within each size. Valves were tested for free discharge, submerged and partially submerged conditions.

With the extensive amount of test data, modeling programs were developed and used to provide hydraulic characteristic curves for every Tideflex® Duckbill Check Valve.



A Tideflex® Check Valve being hydraulically tested by an independent laboratory.

In-House Testing

To supplement the independent hydraulic testing, Red Valve continually conducts research, development and testing to improve existing products and to develop new products. In addition, extensive field studies are conducted to validate product design for long-term performance.

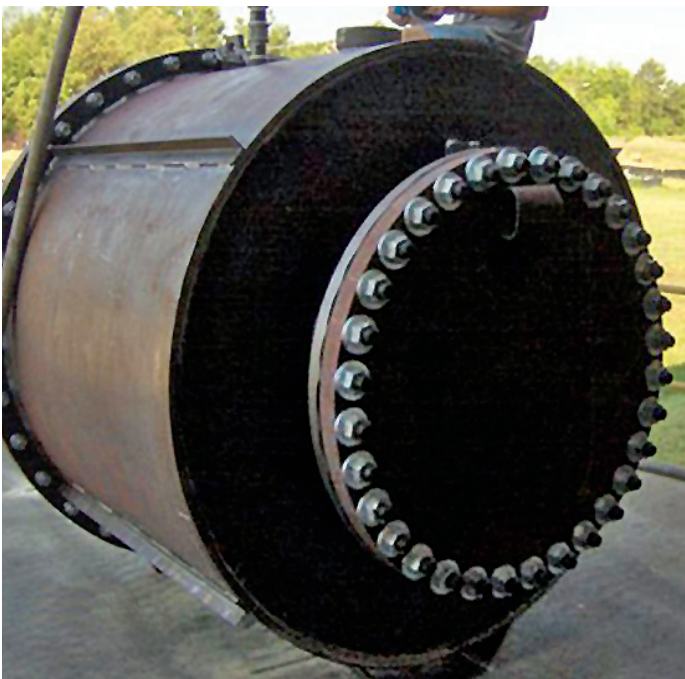

In-house backpressure testing of a 36" Tideflex® Check Valve.



Independent testing of a 48" Tideflex® Check Valve.

Finite Element Analysis (FEA)

From the outside, Tideflex® Duckbill Check Valves appear to be a simple rubber valve manufactured in a duckbill shape. However, for each Tideflex® Check Valve there can be hundreds of layers of various natural and synthetic elastomers and fabric-reinforced plies. This allows Tideflex® Check Valves to be designed for drastically different characteristics such as resilience, durometer, compression set resistance, tensile strength and elongation. Each Tideflex® Check Valve is customized to meet your specific hydraulic needs.

Red Valve has conducted an extensive amount of Finite Element Analysis (FEA) models to analyze the stress, strain, force and deflection characteristics under many load conditions. Modeling was run for discharging and back pressure conditions. These results were used to develop detailed fabrication protocols to ensure Tideflex® Duckbill Check Valves will withstand long-term variable load conditions with favorable hydraulic characteristics.

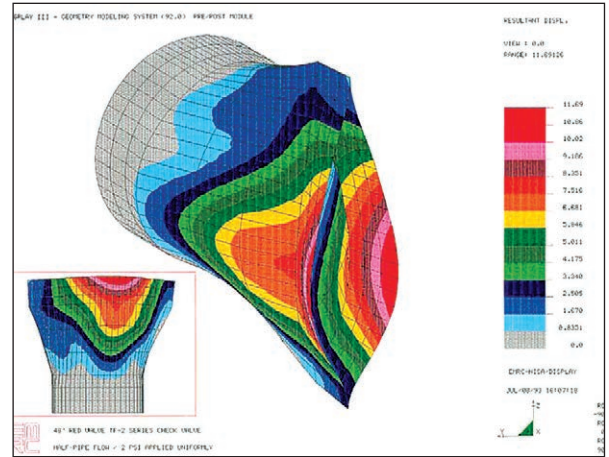

A Finite Element Analysis model of a Tideflex® Check Valve.

Hydraulic Variations

With the extensive amount of data collected, modeling programs were developed that allow us to select the optimal check valve for your unique application needs. Tideflex® Duckbill Check Valves are not “one size fits all.”

There are up to fifty different variations of check valves within each nominal size. Each variation has its own hydraulic characteristics for head loss, jet velocity, effective diameter and backpressure rating. This is achieved by changing the geometry and relative stiffness of the valve.

Tideflex® Check Valves are constructed with many types of elastomers and fabric-reinforced plies. Each material has a different mechanical property. When combined into a unibody construction, the materials produce specific hydraulic characteristics.

Only Red Valve has performed extensive backpressure and hydraulic testing to correlate specific construction details with the backpressure rating and hydraulic performance of each valve.



Various configurations of Tideflex® Check Valves and Diffuser Nozzles.

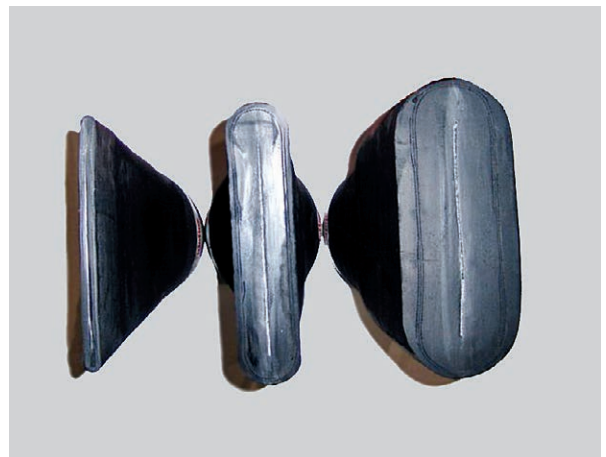

Various stiffnesses of Tideflex® Check Valves showing different bill thicknesses.

Curved Bill Does Not Hinder Ability to Open

The curved bill design of Tideflex® Duckbill Check Valves will not hinder or affect the ability of the valve to open and close, especially in areas where there is sand or silt present. While we do not recommend burying a Tideflex® Check Valve, it will operate in areas of sand or silt much better than a flap gate.

A regional council in Queensland, Australia installed three Curved Bill Tideflex® TF-1 Check Valves along their coastline. Areas along their coastline dealt with low-lying land, tidal inlets, sand drifts, high tides and cyclonic rainfall. As a result, stormwater drainage outlets are often submerged or buried, making it difficult to ensure stormwater is drained and discharged to the ocean.

The council said that while there is little that can be done when high tides are occurring to allow stormwater to dissipate, apart from retention basins, Tideflex® Check Valves can be used to stop saltwater from inundating low-lying areas.

The council also stated the following in regard to the Tideflex® Duckbill Check Valve:

“They also do not get blocked, allowing stormwater to be used to clear away sand when the outlet is buried. There are a number of problems with many traditional stormwater outlets which include being buried by sand with tidal drift causing stormwater flooding, allowing saltwater intrusion into the stormwater drainage system and inundating low-lying land. This results in immediate and long term damage.”

Tideflex® Check Valves can withstand more than 3 meters of inward pressure and do not allow saltwater to enter. The curved bill does not restrict valve operation. Tideflex® Check Valves can be buried in the sand and will allow stormwater to discharge by using the stormwater pressure to clean away the sand. The valve will flow with as little as 50 millimeters of differential water in the pipe.

The council also stated the following about the recently installed Tideflex® Check Valves:

“With the moderate rainfall received recently, we witnessed them [curved bill Tideflex® TF-1 Check Valves] working to remove the sand surrounding the buried valves to allow the water to discharge to the ocean. Previously this has taken a crew and backhoe a number of hours to free the water each time it has either rained or been buried. This is just another example of working smarter and using best practice.”



Views of Tideflex® TF-1 Check Valves installed along coastline. Note the curved bill design of the check valves does not hinder the valve's ability to open and flow in the sand.

Curved Bill Design

As part of Red Valve's commitment to continuous testing and design improvement, our check valves now feature a curved bill as standard on Series TF-1 and Series 35-1, and as an option on our other check valve products.

The curved bill is more resilient than the rest of the valve construction. It reduces head loss across the valve and improves sealing. As a result, the curved bill returns to a closed position more naturally when compared to the original straight bill Tideflex® Duckbill Check Valve design.

The curved bill design improves sealing capability compared to the straight bill. The curved bill allows the valve to form a tighter seal around debris and solids typically found in stormwater and effluent discharge, airport and highway run-off, CSO/SSO systems, ocean outfalls, flood control systems and pumping stations.

The curved bill enhancement is self-draining and does not increase head loss. In fact, head loss is significantly lower with a curved bill.

Testimonial From the Field:

"The City of Monongahela has worked with Red Valve for the past 12 years identifying key locations in our system where absolute back flow prevention is required. Many of our outfall lines are at normal pool elevations or lower. The Tideflex® Check Valves are used specifically to prevent river water from getting into our combined sewer overflow system. By mitigating inflow and infiltration, we are able to prevent backflow, eliminate having to treat clean river water, and we have expanded the capacity of our collection system.

The City of Monongahela converted from using the original Tideflex® Check Valve (TF-2) to the TF-1 eccentric style with the curved bill. We have found that the eccentric valves have lower head loss and the curved bill provides a more effective seal because of its significantly larger sealing area. Tideflex® Check Valves have become an integral part of our regional conveyance projects and have saved us money with reduced maintenance and operational costs."

Ed White
Plant Superintendent
City of Monongahela Sewage Treatment Plant

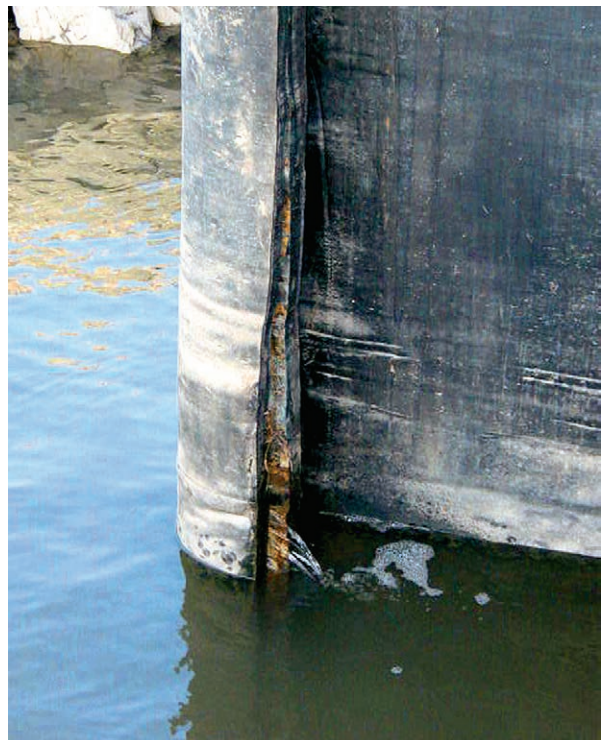

The TF-1 is self-draining and does not increase head loss.



The curved bill of the TF-1 seals tightly around debris.

Eccentric TF-1 Check Valve Geometry and Improved Structure

More than ten years before the original TF-2 Duckbill Check Valve patent expired, the eccentric TF-1 Duckbill Check Valve was introduced because it is stronger, has less head loss and addresses the needs of installations with minimal bottom clearance.

Our most significant technological advancement occurred when the eccentric TF-1 Duckbill Check Valve was tested, patented and introduced. Whether slip-on or flanged, eccentric TF-1 Check Valves are cantilevered when installed at the end of a pipe, flange or headwall. Only the eccentric TF-1 is able to withstand the weight of the valve and the weight of water inside the valve with significantly less deflection.

The TF-1's eccentric geometric design and increased spine angle maximize the structural integrity and performance of the valve. As a result, the eccentric TF-1 has been proven to deflect 30-40% less than the TF-2, minimizing the possibility of sagging. The potential for sagging is significant considering the total weight of the valve and water.

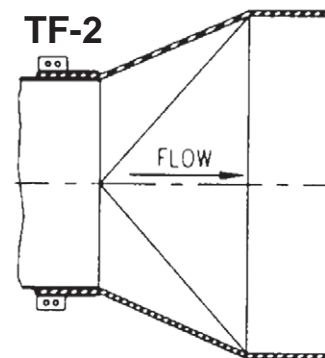
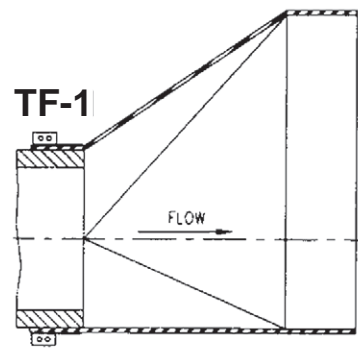

The TF-1 spine is at a greater angle, reducing the cantilever effects of water weight.

PARTS AND WATER WEIGHTS				
VALVE SIZE	TF-1 WEIGHT POUNDS	WATER WEIGHT POUNDS	TOTAL WEIGHT POUNDS	TOTAL WEIGHT TONS
24"	130	637	767	0.3
30"	220	1072	1292	0.6
32"	300	1380	1680	0.7
36"	560	1801	2361	1.1
42"	800	2702	3502	1.6
48"	1027	3855	4882	2.2
60"	1660	7556	9216	4.1
72"	2620	13968	16588	7.4
84"	3880	18411	22291	10.0
90"	4664	23030	27670	12.4

Preferred for Installation in Existing Structures with Minimal Bottom Clearance



- Independent Hydraulic Testing
- Curved Bill Design Enhances Sealing
- Significantly Lower Head Loss
- Improved Structural Integrity
- Eccentric Flat Bottom Design
- Less Bottom Clearance Required
- Increases Flow Capacity

The eccentric Tideflex® TF-1 Check Valve is the preferred check valve for outfalls. Designed for in-structure and end-of-pipe configurations, the TF-1 features a flat bottom and a flared top. This allows the check valve to be installed at a lower overall elevation compared to other configurations because less bottom clearance is required. This is especially important in low-lying areas where maintaining as much driving head as possible is critical, or where silt, sand and debris might collect beneath the valve.

The eccentric TF-1 Check Valve is ideal for applications such as junction boxes, diversion chambers and interceptors where the invert of the pipe is close to the floor of the vault. These structures are designed to maximize the available gravity head, thus the pipe invert is as close to the floor as possible. The TF-1 allows installation in existing structures without the need to break up the concrete floor to achieve bottom clearance. For new structures, construction costs are reduced because the required depth is minimized.



The eccentric TF-1 Check Valve is designed to accommodate installations with little ground clearance.

Increased TF-1 Bill Height Reduces Head Loss

With a maximized bill height that increases the effective open area, head loss in the eccentric TF-1 Duckbill Check Valve is significantly reduced. This unique feature improves flow capacity.

To properly specify an eccentric TF-1 Check Valve you must state the minimum valve height requirement.

Efficiencies are gained and costs are reduced in gravity outfalls and pumped applications. These savings are derived from the larger effective area of the TF-1 and its increased bill height. Systems most impacted are:

- CSO/SSO Systems
- Stormwater Outfall
- Wetlands
- Highway Run-Off
- Effluent Discharge
- Flow Equalization
- Retention Ponds
- Levees
- Site Drainage

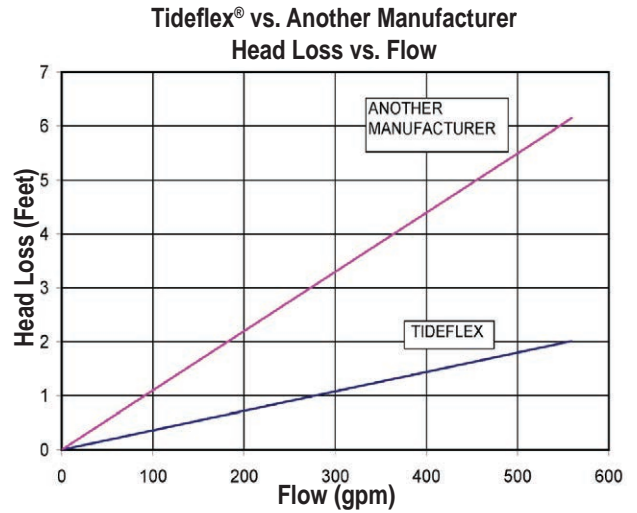

VALVE SIZE	TF-2 HEIGHT	TF-1 HEIGHT	HEIGHT DIFFERENCE	TF-1 HEADLOSS REDUCTION
12"	20"	23"	3"	32%
24"	39"	43"	4"	21%
36"	63"	70"	7"	23%
54"	80"	90"	10"	26%
90"	124"	145"	21"	36%

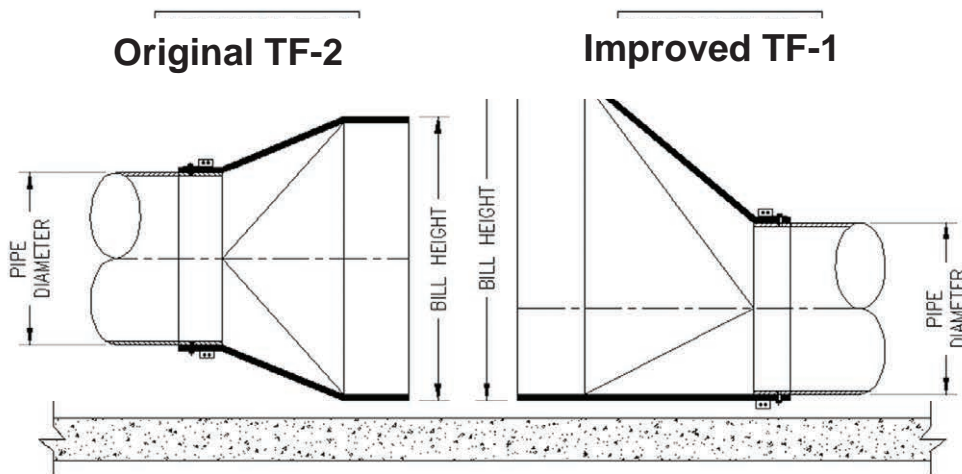

Eccentric TF-1 Check Valves have a greater bill height which increases the effective open area and reduces headloss.

Eccentric TF-1 Check Valves have a greater bill height which increases the effective open area and reduces head loss.

Increased Flow Capacity

The eccentric TF-1 Duckbill Check Valve was developed with a flat bottom to minimize the amount of bottom clearance required below the pipe invert. This allows the valve and pipeline to be lowered, which maximizes driving head. This results in faster drainage, which is especially important in low-lying areas that have limited head available. In structures, the eccentric TF-1 Check Valve does not require as much clearance below the pipe invert which minimizes the amount of debris, sand and sediment that can get trapped.

VALVE SIZE	TF-2 HEIGHT	TF-1 HEIGHT	TF-1 INCREASED DRIVING HEAD
12"	20"	23"	4"
24"	39"	43"	7.5"
36"	63"	70"	13.5"
48"	80"	95"	16"
90"	124"	145"	17"

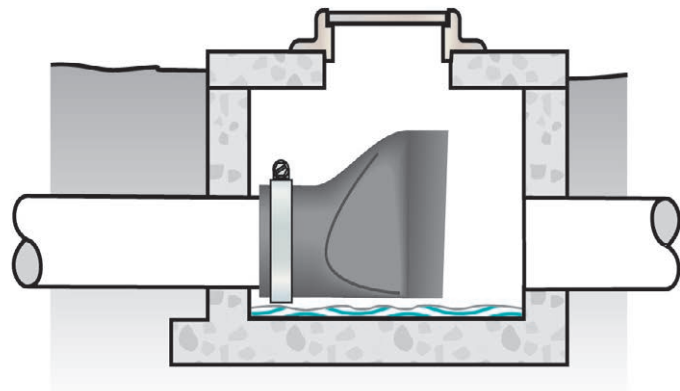

The eccentric TF-1 produces a very small sump because of its low bottom clearance. The amount of sand and sediment that can get trapped in the vault is minimized because normal flow velocities will scour the sump.



The TF-1 spine is at a greater angle than the TF-2, reducing the cantilever effects of water weight.

Original TF-2 Improved TF-1

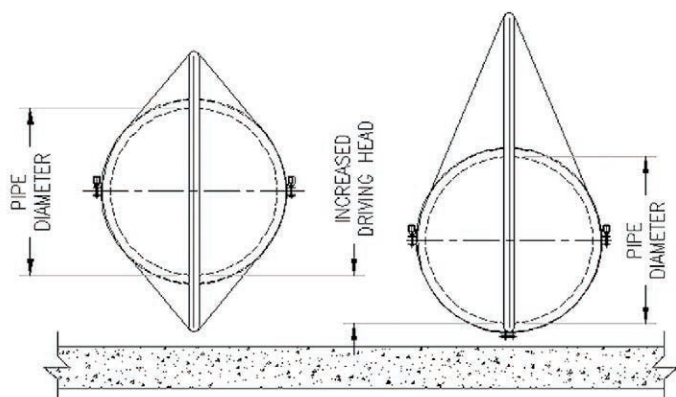

Eccentric TF-1 Check Valves allow for lower pipe invert elevation.



The increased driving head of a TF-1 Check Valve improves flow capacity.

Don't Be Fooled By Other Manufacturers

To gain bottom clearance when installing rubber duckbill valves, other manufacturers will compromise your design and installation by wrongfully advising their valves can be rotated up to 45° from vertical. In sizes 12" and larger, all valves that are installed in a rotated position will distort, gap open and leak.

Most importantly, any rotation compromises the structural integrity of the valve due to an unequal distribution of valve and water weight. Rotating the bill from vertical causes the valve to gap open which results in the valve not being able to seal properly and prevent backflow. Also, considerable distortion of the bill and valve occurs from buoyancy effects on the projected surface area of the rotated bill, resulting in leakage.

The eccentric TF-1 Duckbill Check Valve's flat bottom design allows the bill to be kept in the vertical position and eliminates the possibility of the check valve distorting and gapping open.



Rotating a check valve, as commonly suggested by some manufacturers, will result in distortion, gapping and leakage.

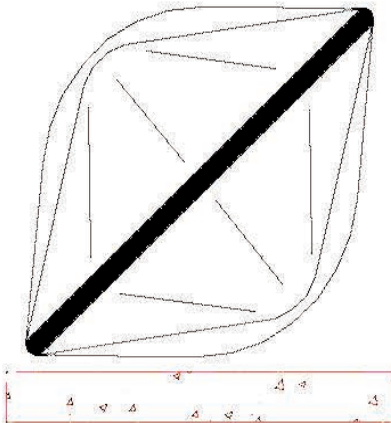

Rubber duckbill check valve rotated to gain bottom clearance.

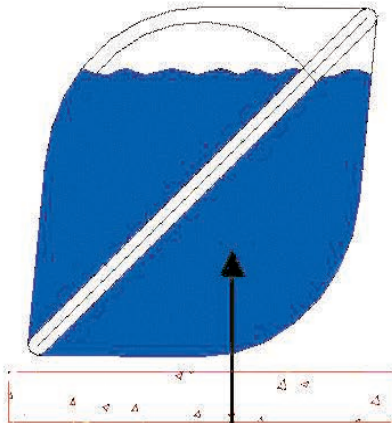

Valve weight + water weight results in excessive load on bottom part of valve.

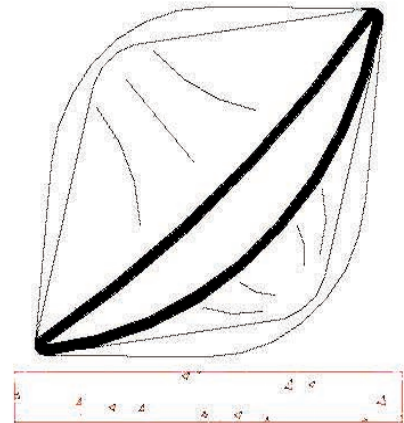

Top part of valve will not deflect as much as the bottom, resulting in the valve gapping open.

Dangers of Altering Pipe Pitch

Another tactic used by other manufacturers is to recommend installing non-eccentric duckbill valves using methods that change the pitch of the pipe, as shown in the illustration below. The invert of the pipe has been raised. This will rob available driving head.

Not only does pitching the check valve create greater head loss, it also allows for standing water to collect inside the pipeline. Standing water will collect and stagnate at the cuff and where the saddle meets the bill. The saddle angles downward past the cuff which will also trap sedimentation and debris.

The drawing below is of a proposed 42" check valve installation offered by another manufacturer. The most significant problem with this installation is there is a 9° angle at the cuff, which raises the invert 7". Driving head is therefore reduced by 7". For example, if the application has a total upstream elevation change of 3 feet (a driving head of 3 feet) the head pressure is reduced 20%.

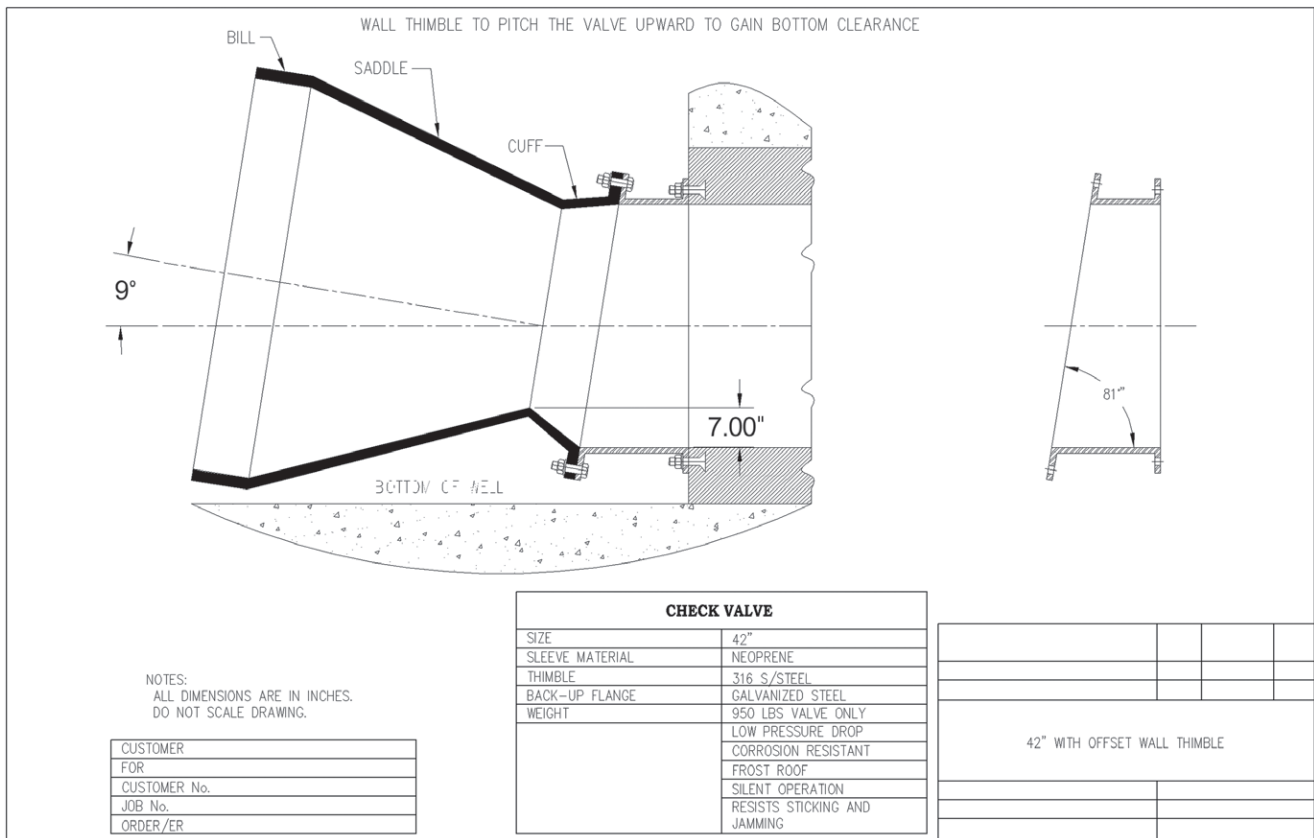

Changing the pitch of a pipe will rob available driving head.

Reducing Cuff Adapters Increases Head Loss

In applications where reinforced concrete pipe is specified, it is essential to understand the impact of the different style valve configurations available. Each option has different effects on price and system performance.

If the determining factor when specifying a Tideflex® Duckbill Check Valve is to keep head loss to a minimum, then your specifications must call for a full-size valve built to fit over the pipe O.D. This ensures the maximum flow capacity at the lowest possible head loss.

Duckbill valves with a reducing cuff, as pictured on the right, have much greater head loss because the valve and its bill height are physically smaller. This alternative is less expensive because the valve uses less material and takes less time to manufacture. Unless specified otherwise, the standard offered by competing duckbill manufacturers is to provide a smaller duckbill valve with a reducing cuff.

The pictures below show several competitor's standard duckbill check valves. Their valves are sized and priced based on nominal pipe I.D., rather than the O.D. of the reinforced concrete pipe.

NOMINAL PIPE I.D.	RCP O.D.	TF-1 HEIGHT BASED ON PIPE I.D.	TF-1 HEIGHT BASED ON PIPE O.D.	HEADLOSS REDUCTION	APPROX. PRICE DIFFERENCE
12"	16"	23"	30"	41%	20%
24"	30"	44"	55"	36%	20%
30"	37"	55"	70"	38%	20%
48"	58"	81"	90"	19%	20%



Competitor A



Competitor B



Competitor C

Check Valve Head Loss Comparison

In the event that price is more important than head loss, Red Valve offers several sizing configurations for reinforced concrete pipe applications.

A representative head loss chart of the various Tideflex® Duckbill Check Valve configurations and the hydraulic impact of each option is shown to the right.

The different Tideflex® Duckbill Check Valve configuration styles are illustrated below.

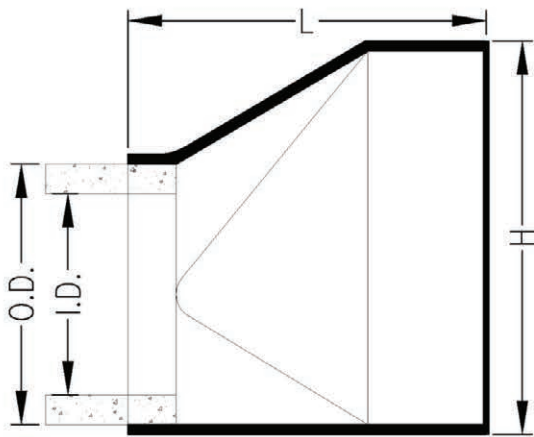
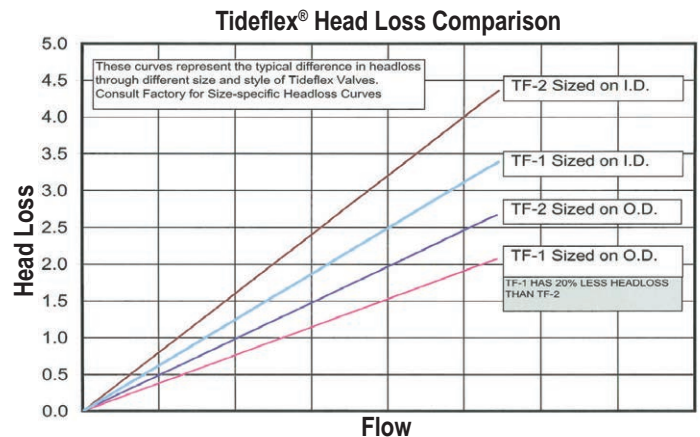

TF-1 sized on Pipe O.D.

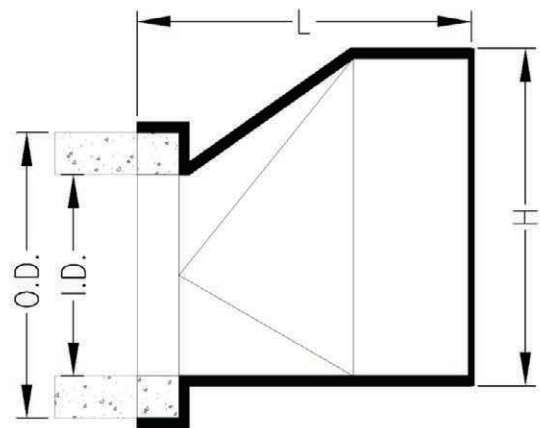

TF-1 with reducing cuff sized on Pipe I.D.

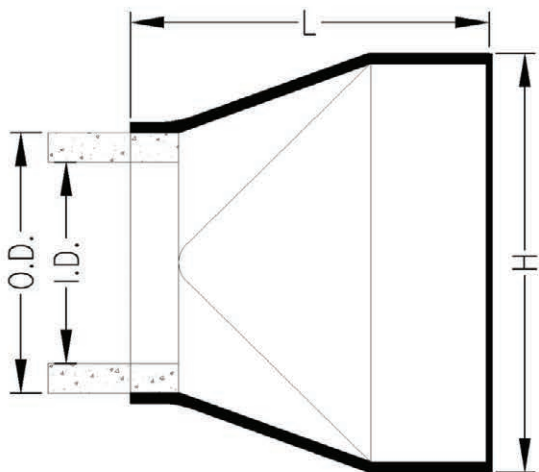

TF-2 sized on Pipe O.D.

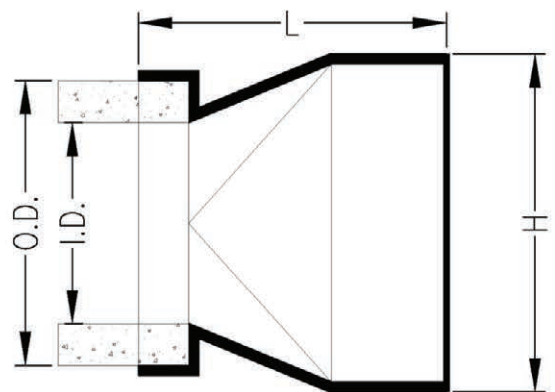

TF-2 with reducing cuff sized on Pipe I.D.

Stiffness

Pictured below are two 6" check valves made for the same operating conditions. The duckbill check valve on the left is a Tideflex®. The valve on the right was made by another valve manufacturer. These check valves were supplied for the same hydraulic conditions. Tests showed that the other manufacturer's valve had three times the head loss as the Tideflex® Check Valve.

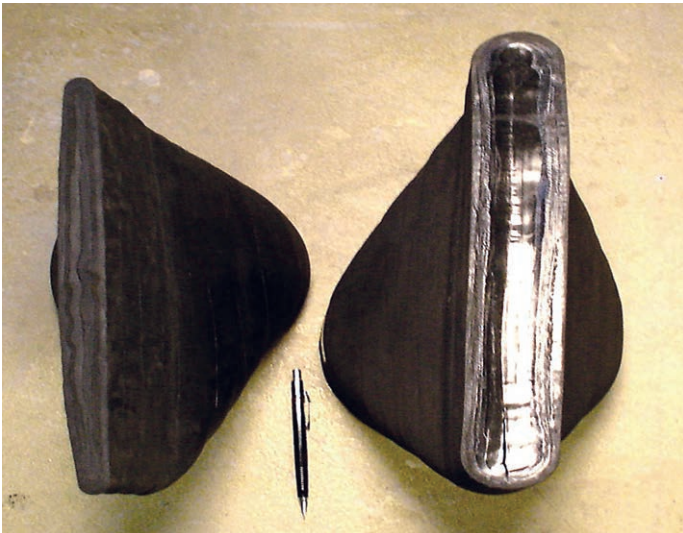

A Tideflex® Check Valve (left) next to a competitor's check valve (right).

Mandrels

Red Valve owns mandrels from 1/2-96". This allows us to build full-sized duckbill check valves every time. Other valve manufacturers construct undersized duckbill check valves due to limited tooling. They will then pass the smaller duckbill check valve off as a larger sized valve by simply providing a reducing cuff adapter. This has detrimental effects on system hydraulics and performance because undersized valves create additional head loss on the system.



A 20" check valve with a 30" cuff, built by another check valve manufacturer. This was passed off as a 30" check valve.

**Tideflex® vs. Another Manufacturer
Head Loss Vs. Flow**

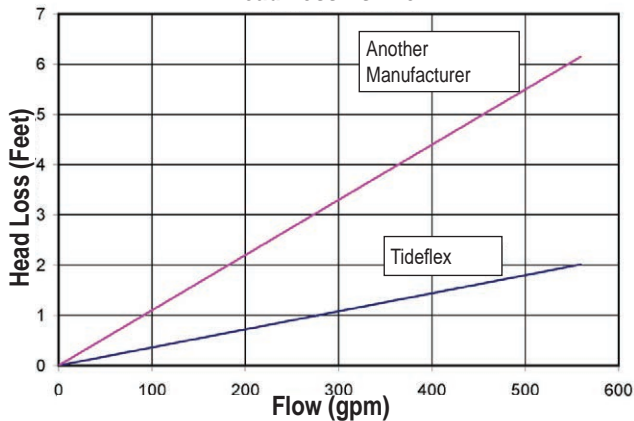

**500mm and 750mm Tideflex®
Head Loss Vs. Flow**

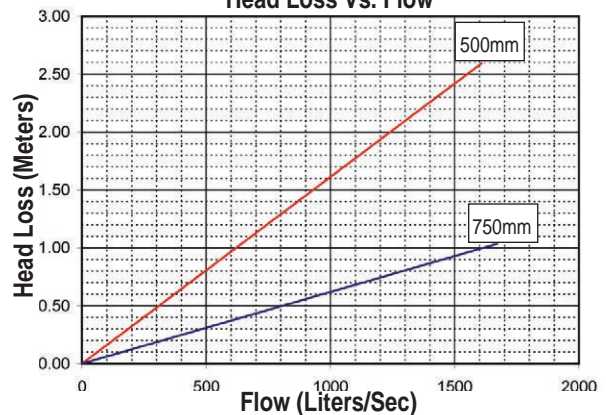

Understand the Difference

Other manufacturers are willing to supply undersized valves to reduce their costs or because of insufficient tooling, regardless of your hydraulic requirements. This results in increased head loss, decreased flow capacity, raised invert elevation, ponding water in the pipe, entrapment of sediment and debris and valves that are prone to inversion.

Tideflex® Check Valves are designed and manufactured in accordance with your hydraulic requirements. Based on our extensive testing and experience, Tideflex® provides full-sized valves that ensure the greatest flow capacity at the lowest head loss.

Tideflex® Check Valve Specifications are available from Red Valve upon request.



(13) 90" Tideflex® Check Valves installed in the Buenos Aires, Argentina, drainage system.

Tideflex® Check Valve Design Data Sheet

I. GENERAL INFORMATION

Project Name:		Advertises On:	
Project Location:		Bids On:	
End User Company Name:		Consulting Engineer Firm:	
County:		Contact:	
Email:		Email:	
Address:		Address:	
Address:		Address:	
City:	State:	City:	State:
Zip:	County:	Zip:	County:
Phone:	Fax:	Phone:	Fax:

II. FLOW CONDITION

<input type="checkbox"/> Stormwater/Drainage	<input type="checkbox"/> Sewage	<input type="checkbox"/> CSO/SSO	<input type="checkbox"/> Other:
<input type="checkbox"/> Pumped		<input type="checkbox"/> Gravity Flow	
Line Pressure (Required for Pumped Systems)	Minimum:	Maximum:	<input type="checkbox"/> Feet <input type="checkbox"/> Meters <input type="checkbox"/> psi <input type="checkbox"/> bar
Flow Rate	Minimum:	Maximum:	<input type="checkbox"/> GPM <input type="checkbox"/> LPS
Max. Backpressure (Calculated to Pipe Invert Level)	<input type="checkbox"/> Feet <input type="checkbox"/> Meters <input type="checkbox"/> psi <input type="checkbox"/> bar		
Bottom Clearance (Distance Beneath Pipe Invert)	<input type="checkbox"/> Inches <input type="checkbox"/> mm		

III. PIPE DETAILS

<input type="checkbox"/> Inches	<input type="checkbox"/> mm
Nominal Pipe Size:	
Pipe O.D.:	
Pipe I.D.:	
Pipe Material:	

IV. CURVED BILL OPTION

<input type="checkbox"/> Yes	<input type="checkbox"/> No
Curved bill is standard on TF-1 and Series 35-1 and check valves size 18" and larger.	

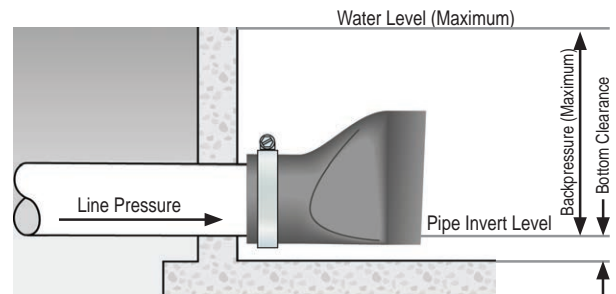

IV. INSTALLATION OPTIONS

Slip On a Pipe	<input type="checkbox"/> TF-1	<input type="checkbox"/> TF-2
Flange Installation	<input type="checkbox"/> Series 35-1	<input type="checkbox"/> Series 35 <input type="checkbox"/> Series 39/39F
Drilling	<input type="checkbox"/> ASME 125/150	<input type="checkbox"/> PIN:
Slip Inside a Pipe	<input type="checkbox"/> Series 37 Flanged	<input type="checkbox"/> Series 37G Insert
Wall Thimble Required (If yes, provide detail drawing of structure/headwall):	<input type="checkbox"/> Yes	<input type="checkbox"/> No

Comments:



Red Valve offers a worldwide, world-class custom service network. With corporate offices in Pittsburgh, PA, manufacturing facilities in Gastonia, NC, and a network of sales representatives around the globe, Red Valve has the sales engineering team to help you select the best choice of valves and related products for your applications.



Red Valve[®]
The World Leader in Pinch and Check Valve Technology™

750 Holiday Drive, Suite 400, Pittsburgh, PA 15220 | 412.279.0044 | support@redvalve.com | RedValve.com

The information presented in this catalog is provided in good faith. Red Valve Company, Inc. and Tideflex[®] reserves the right to modify or improve its design specifications without notice and does not imply any guarantee or warranty for any of its products from reliance upon the information contained herein. All orders are subject to Red Valve Company, Inc. standard terms and warranty and are subject to final acceptance by Red Valve Company, Inc.

Tideflex, Red Valve, and the Red Valve "rv" logo are registered trademarks of Red Valve

© 2025 Red Valve All rights reserved.