

Type A Megaflex Air Operated Pinch Valve Installation, Operation and Maintenance Manual



Red Valve's Type A Megaflex Air Operated Pinch Valve is a 100% full ported bi-directional valve designed for tough slurry applications. The elastomer sleeve closes on entrapped solids in the line. The flexing action of the sleeve breaks up any sediment or build-up in the valve, which makes the Megaflex® a reliable low-maintenance valve.

A variety of elastomers are available to suit your specific needs. Along with the standard Red Valve sleeve, we offer Double Wall (DW), Reduced Port (RP), and Cone Sleeves for special applications.

Standard Type A Megaflex® Valves are constructed to mate with standard ANSI B16.34 150# Series A flanges, which are larger than the nominal pipe size.

- Simple design
- No Packing to maintain, ever
- Cost effective
- No cavities or dead spots to bind valve operation
- Low maintenance

IMPORTANT

Please take a moment to review this manual. Before performing any maintenance on the valve be sure the pipeline has been depressurized. The improper installation or use of this product may result in personal injury, product failure, or reduced product life. Red Valve Company can accept NO liability resulting from the improper use or installation of this product. If you have any questions or problems, please call the customer service hotline at (412) 279-0044.

INSTALLATION

1. INSPECTION OF VALVE:

Check flange faces of pipe for rough/damaged areas. Pipeline flanges must be flat, properly spaced, and parallel to achieve proper seal. PVC flanges may not seal properly, and are not recommended by Red Valve. If PVC flanges are used, metal back up rings must be placed behind the PVC flanges in order to prevent yielding. Typically, PVC flanges will yield before the valve will seal. Pipeline flanges must be serrated approximately 1/16" deep x 90 degrees using an angle tool point. Pitch must be (6) six cuts per inch. This will prevent the "creep" of the rubber flange of the valve sleeve. Flange I.D.'s must match the sleeve I.D. and must be free of sharp edges which could cut into sleeve flanges. **Flanges with an oversized I.D. can cut the sleeve flange, and are not recommended with the Type A Valve** (See Figures 1 & 2). Grind or file any sharp edges of pipeline flange to prevent damage to the sleeve.

CAUTION: Do not use any sharp tools such as a crowbar or screwdriver on the rubber during installation. Sharp instruments can damage the flange face and cause possible leakage.

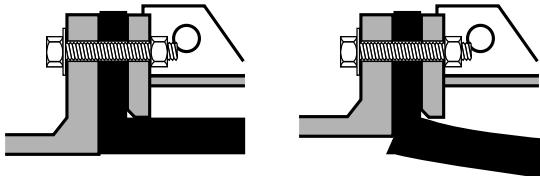

FIG. 1

FIG. 2

2. VALVE ORIENTATION:

The Megaflex® Valve can be installed in any direction in the pipeline. Air connection can be located in any position to permit ease of installation. Always install the valve so one of the 2 drain holes is in the lowest possible position.

CAUTION: Do not introduce full pressure, unregulated plant air to the valve. Excess air pressure can result in premature valve failure. Refer to the operation section and back cover of this manual for correct working air pressure settings.

3. INSTALLING FLANGE BOLTS:

See Figure 3 and Bolting Specification table to determine proper bolt length. For ease of installation, insert all flange bolts through the valve flange and then through the sleeve flange, but do not let the bolts extend beyond the surface of the flange rubber (See Figure 4). Lower the valve into position between the pipeline flanges. As individual bolts line up with the pipeline flange holes, tap the bolt head with a hammer to completely seat the bolt in position. Install a flat washer and nut, hand tight, on the end of the bolt. Repeat until all bolts are seated and have nuts on them.

4. TIGHTENING FLANGE BOLTS & HYDROSTATIC TESTING:

The characteristics of rubber are such that rubber will cold flow. During installation it is necessary to retorque the mating flange bolts numerous times to the recommended torque values to assure proper fastening. The following installation procedure must be followed at all times during installation. Failure to do any one of the following steps may result in damage or failure to the rubber sleeve.

Install valve supports and adjust as necessary to support the weight of the valve before removing the crane cables or forklift truck from the valve. **Both the valve and both ends of the connecting pipeline must be supported. Do not rely on the flange bolting to support the valve or connecting pipeline.**

Do not cover access to the valve and flanges prior to completion of hydrostatic testing since you may need to retorque the flange bolts.

Installation and torquing should be done with the valve in full open position. **Whenever flange bolts are tightened the torquing sequence must be done in a star pattern** (See Figure 5). The torque should be brought up to the torque value shown in the Bolting Specification table.

The valve should be closed once, taking the valve from the full-open position to full-closed position; then back to the full-open position (this is done at the factory but must be done at the jobsite again).

Once the valve has been cycled, check and retorque the bolts. If the bolts have loosened, increase the torque to the torque value shown in the Bolting Specification table. Note: You may increase the torque on the rubber sleeve up to two times the specified value without causing sleeve or flange damage.

Allow the valve to sit for a minimum of 12 hours before performing any hydrostatic test. Prior to hydro test, check torque values again and bring them up to the torque value shown in the Bolting Specification table.

Begin the hydrostatic test. As pressure builds in the valve, the rubber may again cold flow but this time very slightly. If necessary, it is imperative that the installer torque the bolts back up to the torque value shown in the Bolting Specification table. If a leak occurs at any bolt hole, immediately relieve all operating air pressure and increase bolt torque beyond the torque value shown in the Bolting Specification table in increments of 50 ft.-lbs. until all leaks stop.

Once the line and valve have been hydrostatically tested, check all of the bolts on both flanges one final time to assure a minimum value as shown in the torque value shown in the Bolting Specification table.

Rubber flange construction in the Type A Megaflex sleeves uses multiple plies of various rubber compounds. There is a maximum yield and compression built into the sleeve flange. Once you reach this level, the rubber cannot over compress and all cold flow will max out.

NEVER...

- Use sharp tools on rubber sleeve.
- Apply full pressure unregulated shop air.

DO...

- Use MINIMUM air pressure to extend sleeve life.
- Tighten bolts evenly.

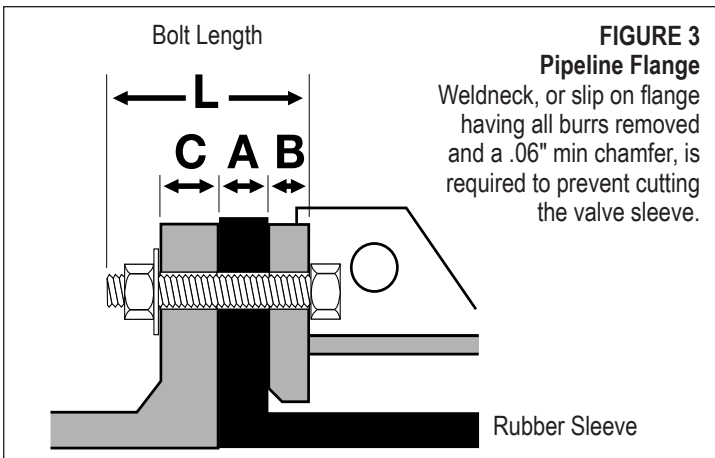

FIGURE 3
Pipeline Flange

Weldneck, or slip on flange having all burrs removed and a .06" min chamfer, is required to prevent cutting the valve sleeve.

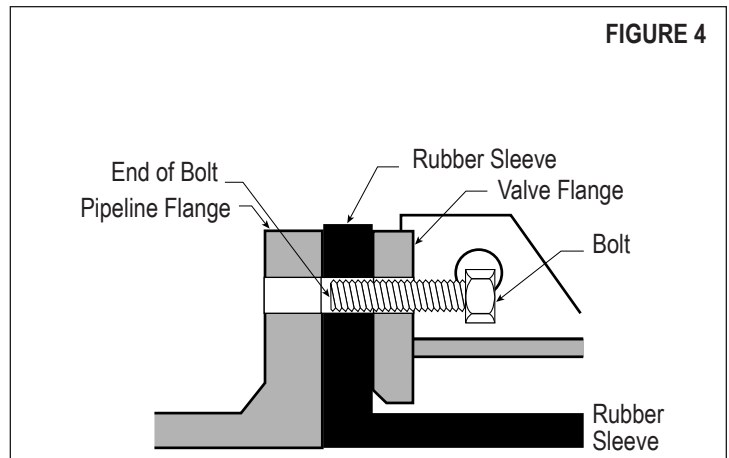

FIGURE 4

MEGAFLEX PINCH VALVE CLOSING AND WORKING PRESSURES

VALVE SIZE	MAXIMUM WORKING PRESSURE (psi)	* AIR CLOSING PRESSURE PURE GUM RUBBER SLEEVES	* AIR CLOSING PRESSURE SYNTHETIC SLEEVE (EXCEPT VITON)	* AIR CLOSING PRESSURE FOR VITON SLEEVE
30"	50	34	45	65
36"	50	34	45	65
42"	50	34	45	65
48"	50	34	45	65

* Air closing pressure above the line pressure for complete closure.

MEGAFLEX INSTALLATION FLANGE BOLTING SPECIFICATIONS

VALVE SIZE	FLANGE SIZE	NO. OF BOLTS	BOLT CIRCLE DIAMETER	BOLT LENGTH (recommended)	L	A	B	PER ANSI	BOLT TORQUE (ft. lbs)
								B16.47 CLASS 150 SERIES A C	
30"	36"	32	42.75"	9"	9"	1.75"	1.50"	3.56"	230
36"	42"	36	49.50"	9"	9"	1.50"	1.50"	3.81"	250
42"	48"	44	56.00"	10"	10"	2.00"	2.00"	4.25"	250
48"	54"	44	62.75"	11"	11"	2.00"	2.00"	4.75"	400

- Torque values are suggested minimum values.
- Torque all flange bolts in a star pattern. First to 50% of tabulated values, then re-torque to 100% of tabulated values. If greater torque is required, continue re-torquing in increments of 50 foot-pounds.

- Variables such as surface finish on bolt threads, type of anti-sieze compound used, and surface finish of the mating flanges all have an effect on the minimum torque required to obtain a leak tight flange seal.
- Use of a high quality anti-sieze compound on all bolt threads is recommended.

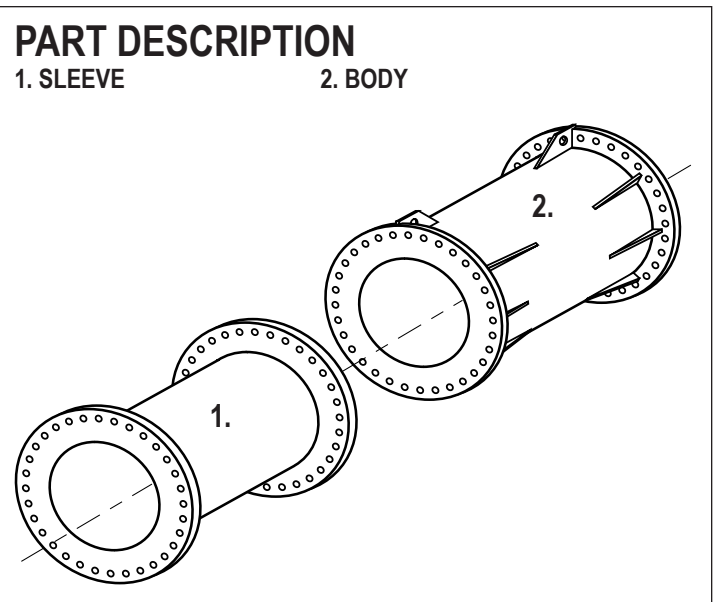
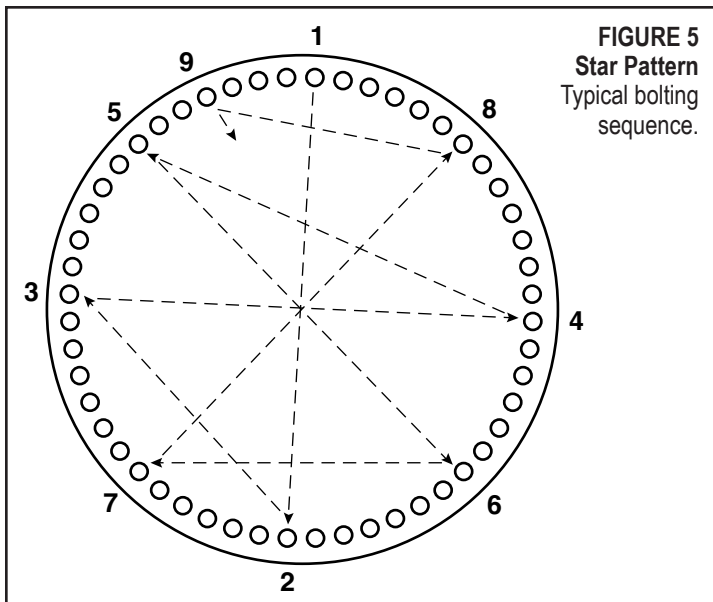

OPERATION

THE MOST CRITICAL FACTOR FOR SUCCESSFUL OPERATION OF RED VALVE'S TYPE A MEGAFLEX® VALVE IS USING A MINIMUM AMOUNT OF AIR PRESSURE TO OPERATE THE VALVE !

The amount of air pressure required to close the valve depends upon the line pressure of the pipeline.

Red Valve's standard Full Port Pure Gum Rubber sleeve requires about 34 psi above line pressure for closure. An increase in plant air pressure may be required for other sleeve designs and materials, depending upon the choice of elastomer. Refer to the Closing and Working Pressure table for working air pressure settings.

NOTE: Air pressure must be vented from valve to permit opening.

STORAGE

If your Megaflex® Valve is to be stored for a period of time prior to installation, the following storage guidelines will help preserve your valve and assure a trouble free installation.

1. Store valve in a clean, cool, dry location. Avoid exposure to light, electric motors, dirt or chemicals.
2. Store valve to prevent other items from contacting sleeve or flanges to prevent possible damage.
3. Store this manual with valve, so that it is readily available at time of installation.

MAINTENANCE

INSPECTION:

Valves should occasionally be inspected for damage and wear. The inspection period should be determined by the severity of the service and environment. If valves are periodically inspected and preventive maintenance done, the valve will last longer and operate better.

CAUTION: Do not remove any valve parts or bolting with pressure in the line. It is easy to inspect the valve for obvious problems.

ELASTOMER SLEEVE REPLACEMENT:

1. A spare replacement sleeve should be placed on order when this valve is placed in service.
2. Do not clean the body end flange surfaces with rough abrasive wheels, or else the serrations will be removed and flange leakage may result. Do not use Permatex or RTV silicone on the metal flange surface. These compounds will fill in the serrations and flange leakage may result.
3. Remove the old sleeve by bending the flanges at one end and withdrawing the sleeve from the other end. See instructions supplied with spare sleeve.
4. Replacement sleeves are made with one flange end slightly softer than the other. This end will be marked. Bend the flange on the softer end towards the centerline of the valve and insert into the body. Insert all the way through the opposite body flange. See instructions supplied with spare sleeve.
5. Allow the sleeve flange to return to its original position.
6. Install the valve back into pipeline following installation procedure.

TROUBLESHOOTING GUIDE

SYMPTOM:

AIR LEAKAGE AT FLANGE

- Retighten all flange bolts in a star pattern in order to extrude rubber sleeve flange material.

SYMPTOM:

SLEEVE RUPTURE (At juncture of flange and body)

- Excess closing pressure.

SLEEVE RUPTURE (At mid point of sleeve)

- Water hammer or pressure surge.
- High velocity of abrasive media with valve cracked open.

SYMPTOM:

VALVE WILL NOT SEAL

- At low temperatures, hardness of the sleeve may increase. Actuate valve 25 to 50 times with pressure to "break in" sleeve.

SYMPTOM:

VALVE WILL NOT OPEN

- Air pressure not vented from body.

SYMPTOM:

CUTS ON FLANGE SURFACE

- Sharp I.D. of mating flange.
- Oversized I.D. of mating flange.



Limited Warranty

Red Valve Company ("Seller") manufactured products, auxiliaries and parts thereof that we manufacture for a period of twenty-four (24) months from date of shipment from Seller's factory, are warranted to the original purchaser only against defective workmanship and material, but only if properly stored, installed, operated, and serviced in accordance with Seller's recommendations and instructions.

For items proven to be defective within the warranty period, your exclusive remedy under this limited warranty is repair or replacement of the defective item, at Seller's option, FCA Incoterms 2020 Seller's facility with removal, transportation, and installation at your cost.

Products or parts manufactured by others but furnished by Seller are not covered by this limited warranty. Seller may provide repair or replacement for other's products or parts only to the extent provided in and honored by the original manufacturer's warranty to Seller, in each case subject to the limitations contained in the original manufacturer's warranty.

No claim for transportation, labor, or special or consequential damages or any other loss, cost or damage is being provided in this limited warranty. You shall be solely responsible for determining suitability for use and in no event shall Seller be liable in this respect.

This limited warranty does not warrant that any Seller product or part is resistant to corrosion, erosion, abrasion or other sources of failure, nor does Seller warrant a minimum length of service.

Your failure to give written notice to us of any alleged defect under this warranty within twenty (20) days of its discovery, or attempts by someone other than Seller or its authorized representatives to remedy the alleged defects therein, or failure to return product or parts for repair or replacement as herein provided, or failure to store, install, or operate said products and parts according to the recommendations and instructions furnished by Seller shall be a waiver by you of all rights under this limited warranty.

This limited warranty is voided by any misuse, modification, abuse or alteration of Seller's product or part, accident, fire, flood or other Act of God, or your failure to pay entire contract price when due.

The foregoing limited warranty shall be null and void if, after shipment from our factory, the item is modified in any way or a component of another manufacturer, such as but not limited to; an actuator is attached to the item by anyone other than a Seller factory authorized service personnel.

All orders accepted shall be deemed accepted subject to this limited warranty, which shall be exclusive of any other or previous warranty, and this shall be the only effective guarantee or warranty binding on Seller, despite anything to the contrary contained in the purchase order or represented by any agent or employee of Seller in writing or otherwise, notwithstanding, including but not limited to implied warranties.

THE FOREGOING REPAIR AND REPLACEMENT LIMITED WARRANTY IS IN LIEU OF ALL OTHER WARRANTIES, OBLIGATIONS AND LIABILITIES, INCLUDING, BUT NOT LIMITED TO, ALL WARRANTIES OF FITNESS FOR A PARTICULAR PURPOSE OR OF MERCHANTABILITY OR OTHERWISE, EXPRESSED OR IMPLIED IN FACT OR BY LAW, AND STATE SELLER'S ENTIRE AND EXCLUSIVE LIABILITY AND YOUR EXCLUSIVE REMEDY FOR ANY CLAIM IN CONNECTION WITH THE SALE AND FURNISHING OF SERVICES, GOODS OR PARTS, THEIR DESIGN, SUITABILITY FOR USE, INSTALLATION OR OPERATIONS. NEITHER ANY PERFORMANCE OR OTHER CONDUCT, NOR ANY ORAL OR WRITTEN INFORMATION, STATEMENT, OR ADVICE PREPARED BY SELLER OR ANY OF OUR EMPLOYEES OR AGENTS WILL CREATE A WARRANTY, OR IN ANY WAY INCREASE THE SCOPE OR DURATION OF THIS LIMITED WARRANTY.

Limitation of Liability

IN NO EVENT SHALL SELLER BE LIABLE FOR ANY DIRECT, INDIRECT, SPECIAL, PUNITIVE, EXEMPLARY, OR CONSEQUENTIAL DAMAGES (INCLUDING, BUT NOT LIMITED TO, DAMAGE TO OR LOSS OF OTHER PROPERTY OR EQUIPMENT, BUSINESS INTERRUPTION, COST OF SUBSTITUTE PRODUCTS, LOSS OF TIME, LOSS PROFITS OR REVENUE, COST OF CAPITAL, LOSS OF USE, OR DIMINUTION IN VALUE) WHATSOEVER, AND SELLER'S LIABILITY, UNDER NO CIRCUMSTANCES, WILL EXCEED THE CONTRACT PRICE FOR THE GOODS AND/OR SERVICES FOR WHICH LIABILITY IS CLAIMED. ANY ACTION FOR BREACH OF CONTRACT BY YOU, OTHER THAN RIGHTS RESPECTING OUR LIMITED WARRANTY DESCRIBED ABOVE, MUST BE COMMENCED WITHIN 12 MONTHS AFTER THE DATE OF SALE.

Sales and Service

For information about our worldwide locations, approvals, certifications and local representative:

Web site: RedValve.com E-Mail: support@redvalve.com



750 Holiday Drive, Suite 400, Pittsburgh, PA 15220 • Phone: 412-279-0044

Red Valve Company reserves the right to incorporate our latest design and material changes without notice or obligation. Design features, materials of construction and dimensional data, as described in this manual, are provided for your information only and should not be relied upon unless confirmed in writing by Red Valve Company. Certified drawings are available upon request.