

# Tideflex® Series TFD / Series TF1D Diffuser Nozzles

## Installation, Operation and Maintenance Manual

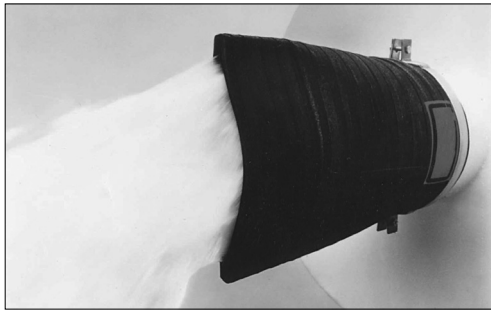

**TF-D**



**TF-1D**

The revolutionary design of the all-rubber Tideflex® Diffuser Nozzles provides reliable backflow protection. This unique duck bill design eliminates costly backflow from oceans, rivers or stormwater, and is the ideal nozzle for effluent diffuser systems.

Tideflex® Diffuser Nozzles seal on entrapped solids and debris without jamming. Unlike traditional flap gates there are no hinged gates to hang open, and there is no warping or freezing. It's virtually maintenance-free.

The Tideflex® Diffuser Nozzle is available in a wide variety of elastomers and is designed to meet your exact flow specifications.

### IMPORTANT

Please take a moment to review this manual. Before performing any maintenance on the valve be sure the pipeline has been de-pressurized. The improper installation or use of this product may result in personal injury, product failure, or reduced product life. Tideflex® can accept NO liability resulting from the improper use or installation of this product. If you have any questions or problems, please call the customer service department at (412) 279-0044. We appreciate your comments. Thank you for choosing Tideflex®.

# GENERAL DESCRIPTION

The Tideflex® Diffuser Nozzle is an all-elastomer, one-piece diffuser nozzle. Terms used in this IOM to refer to various parts of the nozzle are described below.

1. Cuff - the cuff is designed with a full round bore and slips over the end of the pipe.
2. Saddle - The saddle is the middle part of the nozzle, tapering from the round cuff to the flat bill. The saddle directs the flow to the bill, and is flexible to sustain increased flow conditions.
3. Bill - the bill is the discharge end of the nozzle. The bill flexes to allow flow to discharge, yet is stiff enough to prevent the nozzle from opening without line pressure.  
Backpressure, the pressure created on the exterior of the nozzle by reverse flow or submersion, will seal the lips of the bill tightly together, preventing backflow into the nozzle.
4. Clamps - The clamps are tightened around the cuff after the cuff has been slipped over the end of the discharge pipe. These clamps are normally furnished by Red Valve. Hose clamps are supplied for nozzles up to 12". Nozzles 14" and up are supplied with fabricated clamps. 14"-20" are supplied with one set, 20"-54" are supplied with two sets, and sizes 60" and up are supplied with three sets.
5. Lifting clevis - lifting clevis is attached to the bill of the diffuser nozzle for valves 36" and up. This clevis is used during installation to assist in lifting the valve, and may be used to attach a line to the bill to help support the nozzle after installation.

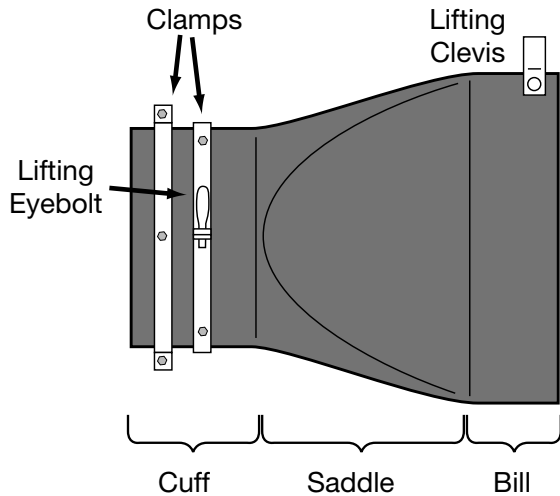

# OPERATION

Tideflex® Diffuser Nozzles are custom made products intended for a specific application and have been designed to respond to criteria unique to that purpose, such as line pressure, minimum and maximum backpressure and chemical compatibility. Should the conditions for which the valve has been designed be altered or change in any way, it could affect the normal operation of the nozzle.

Tideflex® Diffuser Nozzles work on backpressure exerted on the bill area to seal the nozzle. The bill may appear to be slightly open when installed. This slight opening does not affect the operation of the nozzle as the nozzle depends on backpressure to seal.

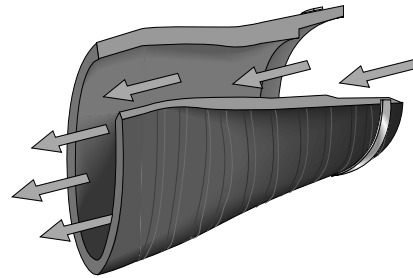

Forward Pressure Opens Nozzle

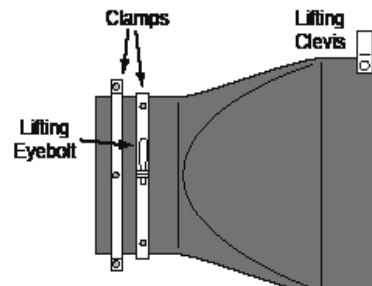

Reverse Pressure Seals Nozzle

## IMPORTANT

The nozzle shall be installed with the bill in the vertical position.

### NEVER...

Cut or modify diffuser nozzle.

### DO...

Use a soapy water solution to slide diffuser nozzle on pipe.

### DO...

Keep nozzle on pallet until ready to install.

### DO...

Tighten clamp bolts evenly.

# STORAGE

Tideflex® Diffuser Nozzles should be stored in a cool, dry location on original shipping pallet with the bill facing upward, not on its side (see Figure 2). Do not drop, bend or twist diffuser nozzle, or damage may occur.

1. Store valve in a cool, clean, dry location.
2. Avoid exposure to light, electric motors, dirt or chemicals. Resilient diffuser valves are subject to deterioration when exposed to ozones and non-compatible chemicals. Ozone especially causes age hardening of the elastomer.
3. Store Installation Operation Manual with product so it will be readily available for installation.
4. Do not remove wooden brace or metal shipping ring (36"+) until diffuser nozzle is installed.

Figure 2

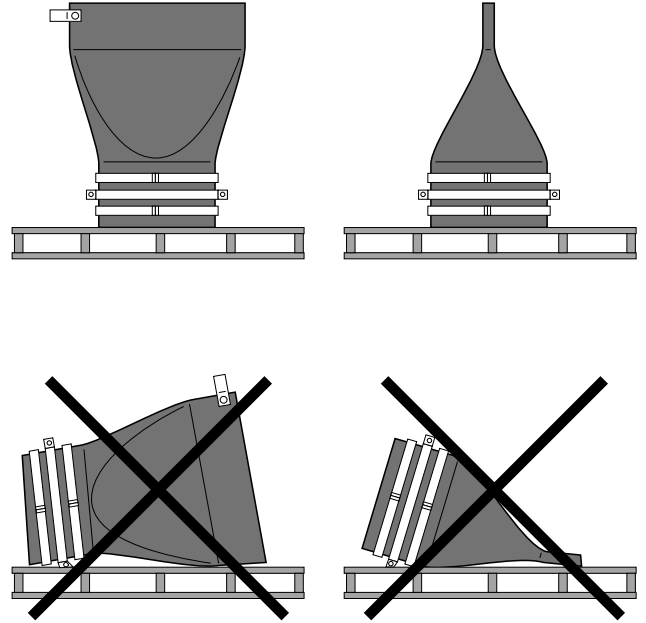

**NEVER STORE HORIZONTALLY**

## INSTALLATION INSTRUCTIONS TIDEFLEX® CHECK VALVES

### 1. INSPECTION OF DIFFUSER NOZZLE

Check the inside diameter of the cuff of the Tideflex® Diffuser Nozzle to compare it to the O.D. of the outfall pipe. Inspect the outfall pipe for sharp or damaged areas. The pipeline should be in a smooth condition to prevent cutting the rubber nozzle. Lifting clevis and lifting eye bolts are provided only for sizes 36" and over.

Imperfections on the inside of the cuff area can be filled with a silicone sealant prior to installing the nozzle on the pipe. This will ensure a seal in the cuff area after clamps are tightened.

### 2. INSPECTION OF THE PIPE

Check the outside diameter of the pipe to determine if it matches the I.D. of the cuff of the Tideflex® Diffuser Nozzle. The cuff of the nozzle is usually made slightly larger to permit ease of installation.

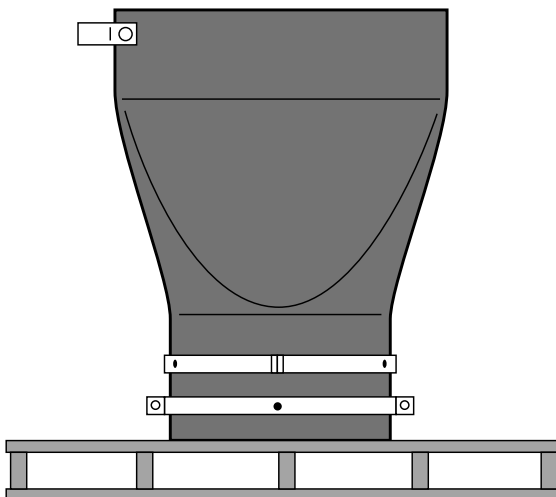

### 3. CLEARANCE

Make certain that sufficient ground clearance exists below the valve, at least 10% of the valve diameter (i.e. 6" for a 60" valve).

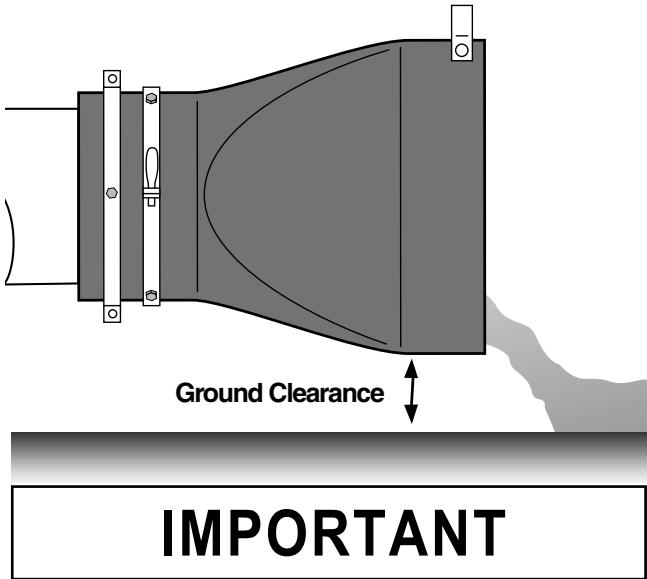

### 4A. TIDEFLEX® WITH CURVED BILL INSTALLATION IN CURRENT

For Tideflex® Diffuser Nozzles fabricated with a curved bill, the nozzle should be installed so the bill points in the direction of the current, not facing the current which may cause the bill to be forced open.

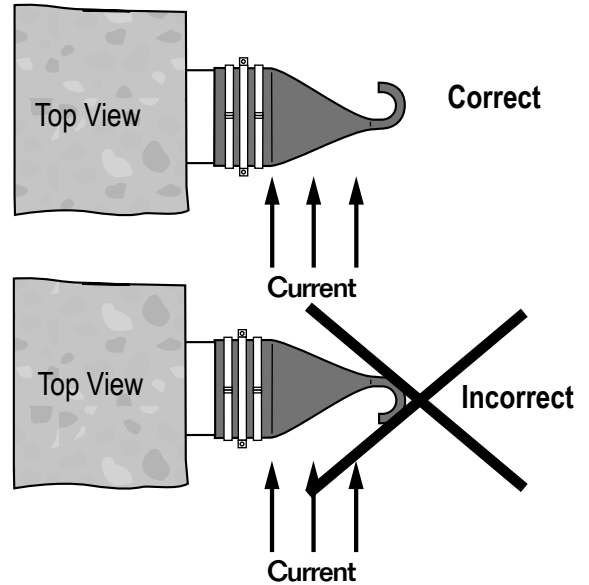

### 5. REMOVING THE NOZZLE FROM PALLET OR CRATING

A lifting clevis is provided at the top end of the Tideflex® Diffuser Nozzle. Lifting eye bolts are provided on the clamps. Remove the cuff retainer shipping ring or wooden brace located inside the cuff of the nozzle. The nozzle should be lifted from the pallet using both the clevis and the lifting eye bolts.

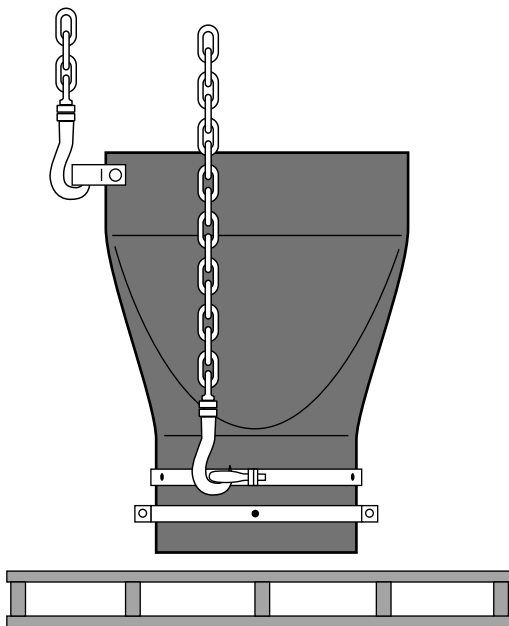

### 4B. FITTING TIDEFLEX® ON PIPE

- A. To facilitate insertion of the pipe into the Tideflex® Diffuser Nozzles, it might be necessary to grind a bevel on the inside cuff diameter.
- B. Sometimes it is necessary to grind the inside of the cuff or add gasket material to the O.D. of the pipe to properly fit the Tideflex® Diffuser Nozzle.

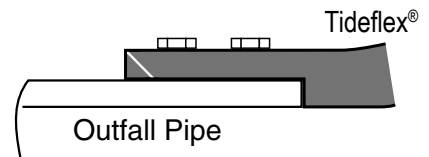

### 6. LIFTING THE NOZZLE

Do not discard the metal clamps holding the nozzle onto the pallet. THESE CLAMPS ARE NEEDED to install the Tideflex® Diffuser Nozzle. In lifting the Tideflex® Diffuser Nozzle from the pallet, keep the bill end of the Tideflex® higher than the cuff for ease of installation.

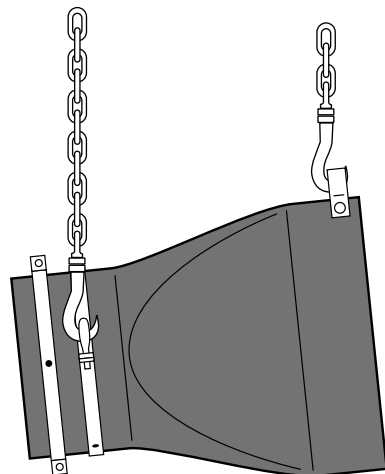

## 7. POSITIONING THE DIFFUSER NOZZLE

Apply a soap/water solution to the outside of the pipe in which the Diffuser Nozzle is being installed on, to ease installation.

### TF-D

With the bill end of the Tideflex® lifted higher than the cuff end start to fit cuff on the outfall line. The Tideflex® Diffuser Nozzle should fit snugly against the outfall pipe, leaving no gap.

### TF-1D

Flat portion of the valve to be at the bottom of the pipe. Flare to be at the top.

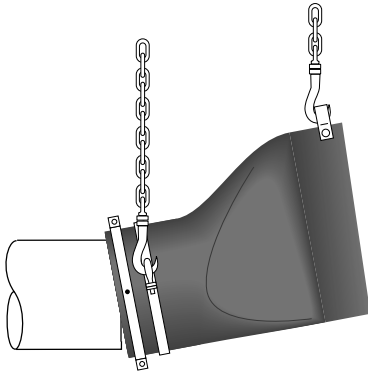

After the unit is securely pegged into position, proceed to install and tighten the first clamp. A mild lubricant may be applied to the I.D. of the clamp to prevent a brake shoe effect when tightening down the clamps.

## 9. POSITIONING FOR TWO CLAMPS

Install the second clamp on the cuff of the Tideflex®. Rotating the clamp 90° in relation to the first clamp will ensure even pressure around the nozzle and pipe, thus increasing the effectiveness of the clamps.

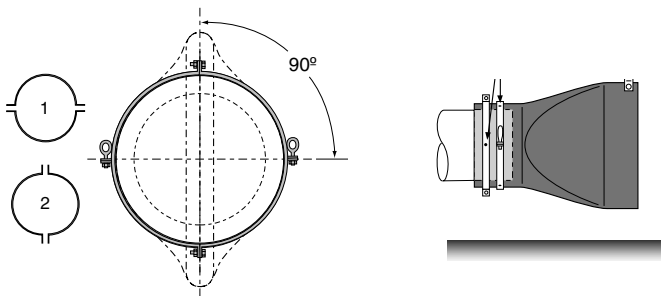

If a greater distance between the angles of the clamps is required to provide more range for tightening the bolts, especially if angles are bottoming out, gasket material can be wrapped around the O.D. of the cuff as shown.

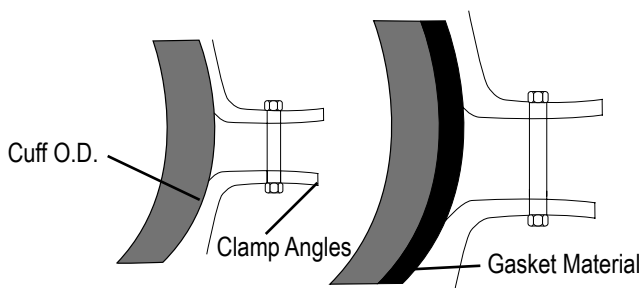

## 8. SEAT TIDEFLEX® ON PIPE

The Tideflex® Diffuser Nozzle should fit snugly against the outfall pipe, leaving no gap. If possible, inspect installation from the inlet end of the Tideflex® Diffuser Nozzle to insure that the Diffuser Nozzle cuff fits snugly on the pipe. Do not allow a gap between the cuff and the end face of the outfall pipe. A gap will create an imbalance which will not provide proper support for the Tideflex® Diffuser Nozzle. For more information, see troubleshooting.

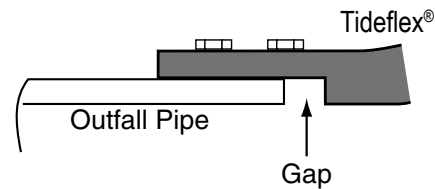
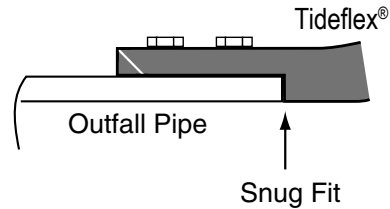

## 10. POSITIONING FOR THREE CLAMPS

After the unit is securely pegged into position, proceed to install and tighten the first clamp. A mild lubricant may be applied to the I.D. of the clamp to prevent a brake shoe effect when tightening down clamps.

Install the second and third clamps on the cuff of the Tideflex®. Rotating the first and second clamps 60° and 120°, respectively, in relation to the first clamp will ensure even pressure around the nozzle and pipe, thus increasing the effectiveness of the clamps.

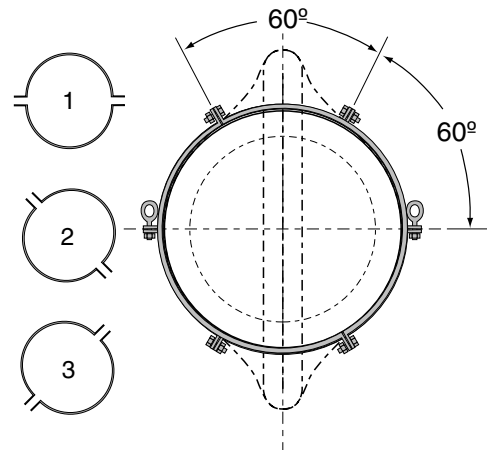

## 11. POSITIONING BLANK HOLES IN CLAMPS

Tighten all clamps and bolts once all components have been positioned properly. Pre-drilled holes are drilled in each clamp. These are provided so as to secure the Tideflex® Diffuser Nozzle with holding pins to the outfall pipe. This will secure the Tideflex® Diffuser Nozzle to the pipe and assure a long, trouble-free service life. After tightening the clamps, the pre-drilled holes should be staggered. Holes are not drilled in the rubber cuff of the Tideflex® at the factory since they would not line up to the tightened clamps.

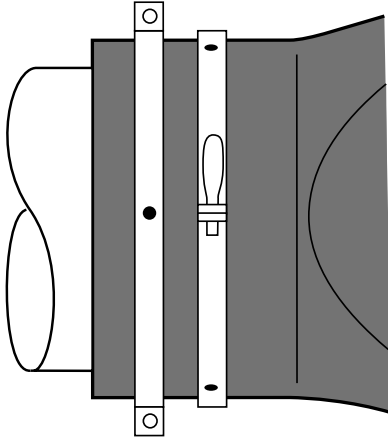

## 12. TACK WELDING HOLDING BOLTS TO CLAMPS

Once clamps are secure use a standard steel drill bit and drill holes through the rubber cuff. Insert holding bolts through the cuff and secure opposite side with nut, if possible. Holding bolts should be stainless steel. Steel bolts can corrode and break off, causing the diffuser nozzle to slip off the pipe. Holding bolts are not provided because of various widths of the outfall pipe.

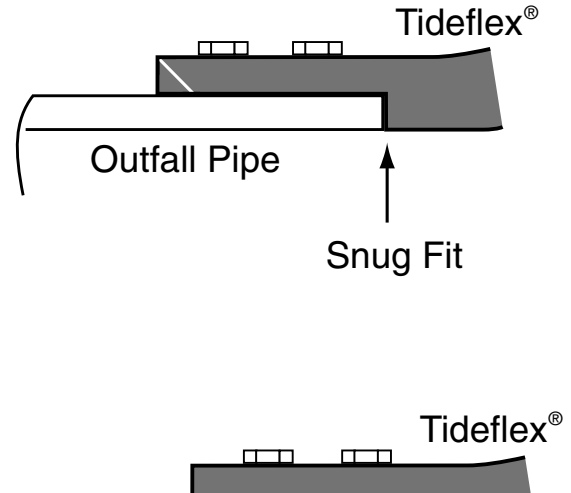

## 13. BOLTS TACK WELDED TO CLAMPS

After tightening, heads of holding bolts can be tack welded to the clamps using small tacks. Certain installations will not permit installing of nuts to bolts. In these situations, the tightness of the clamps and tack weld of the bolts will assure good support.

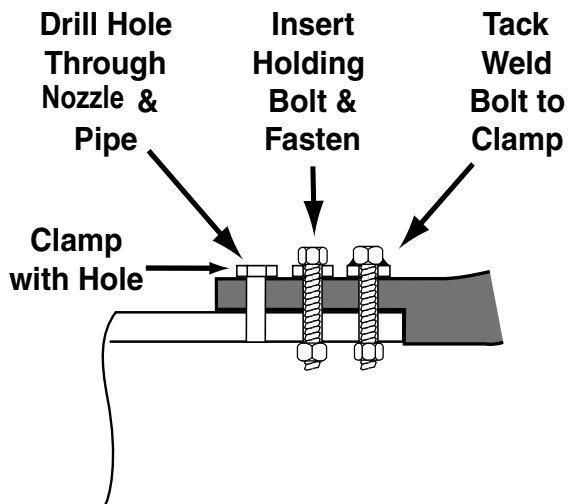

## 14. CORRUGATED PIPE AND SMOOTH WALL (PVC, HDPE) PIPE INSTALLATION

For installation on corrugated pipe, it is recommended that the corrugations be filled with hydraulic cement (or similar material) that will provide a smooth O.D.

For smooth wall pipe, it is recommended that the nozzle be pinned.

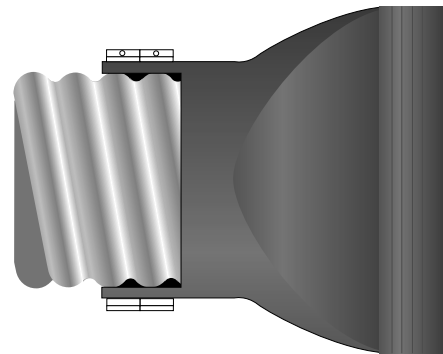

# TROUBLESHOOTING

## Diffuser Nozzle will not fit to pipe:

- Make certain that the inside cuff retainer ring has been removed prior to fitting the nozzle to the pipe.
- Verify that the nozzle has enough area to fit over the pipe.
- If the pipe can be removed, or if an adapter ring which bolts to the wall or inside a vault is used, a crane or high-lift may be used to lower the nozzle onto the ring with the nozzle turned on end and the bill facing up.

## Diffuser Nozzle will not close fully, or check flow in opposing direction:

- Possible obstruction in line. Inspect the nozzle for entrapped foreign objects which may have lodged between the lips of the nozzle.
- Nozzle may not be installed high enough to clear the ground under the bill. Ensure that there is enough space between the bottom of the nozzle and the ground in order to prevent contact of the two or debris build-up.
- Backpressure may not be sufficient to completely seal the nozzle.
- The nozzle may not have been installed in a vertical position.

## Diffuser Nozzle will not stay on pipe:

- Check all clamp bolts to assure that all bolts are tightened sufficiently.
- Nozzle may not be fully seated onto outfall line.
- Clamps are not rotated 90° from each other in order to provide adequate holding power.
- Nozzle cuff has a much larger I.D. in relation to pipe O.D.
- Make sure holding pins are used on 42" and larger diffuser nozzles in order to prevent the nozzle from slipping off the line.

TF-D Diffuser Nozzles are designed to slide over a pipe stub. Too short of a pipe stub may cause the diffuser nozzle to slip off or cause the diffuser nozzle to gap open.

For diffuser nozzles up to 4", the pipe stub length "B" should be a minimum of 1/2" longer than cuff depth "A".

6"-14"	1" longer
16"-24"	2" longer
30"-60"	2 1/2" longer
72" and up	3" longer

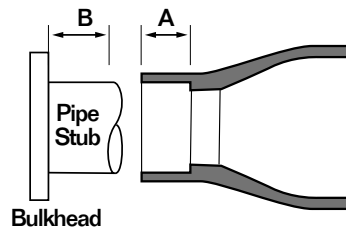

## Hints to install large diameter Diffuser Nozzles:

During the installation of the diffuser nozzle, if force is needed to seat the nozzle to the cuff stop on large diameter diffuser nozzle, the force required should be induced equally around the cuff of the diffuser nozzle, never at only the top, bottom or in the center. The force required to push the diffuser nozzle onto the pipe can be placed on the bill but it should be distributed evenly over the entire length of the bill. Failure to distribute the pressure equally may cause improper performance of the diffuser nozzle. Use a wide angle iron or large wooden planks across the bill to distribute the force equally.

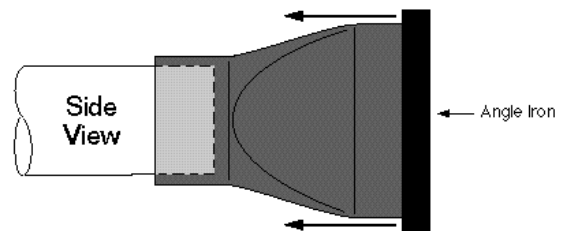
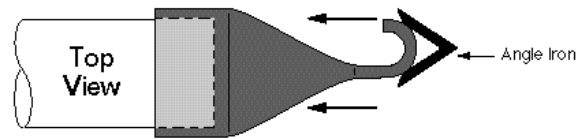
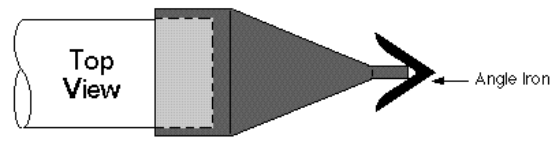

# MAINTENANCE

Line pressure should flush the nozzle clean of debris in most cases. Periodic inspections for trapped debris should be conducted.

In vacation seashore areas quart size plastic bottles have a tendency to float on top and not flush through except during a major storm.

A feathered 1" x 4", 1-1/2" x 12", or suitable plank inserted into the bill of the valve and turned 90° is a simple method of clearing the check valve of small debris which may be trapped between the lips.

**CAUTION:** Sharp objects should not be used on the Tideflex® Diffuser Nozzle, as there is a chance of cutting the rubber and damaging the protective fabric covering.

Any gouges in the cover wrap that occur should be sealed to safeguard against ozone or chemical attack. This is best done with rubber cement or a good brand of silicone or polyurethane rubber sealer made by the major manufacturers.





## Limited Warranty

Red Valve Company ("Seller") manufactured products, auxiliaries and parts thereof that we manufacture for a period of twenty-four (24) months from date of shipment from Seller's factory, are warranted to the original purchaser only against defective workmanship and material, but only if properly stored, installed, operated, and serviced in accordance with Seller's recommendations and instructions.

For items proven to be defective within the warranty period, your exclusive remedy under this limited warranty is repair or replacement of the defective item, at Seller's option, FCA Incoterms 2020 Seller's facility with removal, transportation, and installation at your cost.

Products or parts manufactured by others but furnished by Seller are not covered by this limited warranty. Seller may provide repair or replacement for other's products or parts only to the extent provided in and honored by the original manufacturer's warranty to Seller, in each case subject to the limitations contained in the original manufacturer's warranty.

No claim for transportation, labor, or special or consequential damages or any other loss, cost or damage is being provided in this limited warranty. You shall be solely responsible for determining suitability for use and in no event shall Seller be liable in this respect.

This limited warranty does not warrant that any Seller product or part is resistant to corrosion, erosion, abrasion or other sources of failure, nor does Seller warrant a minimum length of service.

Your failure to give written notice to us of any alleged defect under this warranty within twenty (20) days of its discovery, or attempts by someone other than Seller or its authorized representatives to remedy the alleged defects therein, or failure to return product or parts for repair or replacement as herein provided, or failure to store, install, or operate said products and parts according to the recommendations and instructions furnished by Seller shall be a waiver by you of all rights under this limited warranty.

This limited warranty is voided by any misuse, modification, abuse or alteration of Seller's product or part, accident, fire, flood or other Act of God, or your failure to pay entire contract price when due.

The foregoing limited warranty shall be null and void if, after shipment from our factory, the item is modified in any way or a component of another manufacturer, such as but not limited to; an actuator is attached to the item by anyone other than a Seller factory authorized service personnel.

All orders accepted shall be deemed accepted subject to this limited warranty, which shall be exclusive of any other or previous warranty, and this shall be the only effective guarantee or warranty binding on Seller, despite anything to the contrary contained in the purchase order or represented by any agent or employee of Seller in writing or otherwise, notwithstanding, including but not limited to implied warranties.

THE FOREGOING REPAIR AND REPLACEMENT LIMITED WARRANTY IS IN LIEU OF ALL OTHER WARRANTIES, OBLIGATIONS AND LIABILITIES, INCLUDING, BUT NOT LIMITED TO, ALL WARRANTIES OF FITNESS FOR A PARTICULAR PURPOSE OR OF MERCHANTABILITY OR OTHERWISE, EXPRESSED OR IMPLIED IN FACT OR BY LAW, AND STATE SELLER'S ENTIRE AND EXCLUSIVE LIABILITY AND YOUR EXCLUSIVE REMEDY FOR ANY CLAIM IN CONNECTION WITH THE SALE AND FURNISHING OF SERVICES, GOODS OR PARTS, THEIR DESIGN, SUITABILITY FOR USE, INSTALLATION OR OPERATIONS. NEITHER ANY PERFORMANCE OR OTHER CONDUCT, NOR ANY ORAL OR WRITTEN INFORMATION, STATEMENT, OR ADVICE PREPARED BY SELLER OR ANY OF OUR EMPLOYEES OR AGENTS WILL CREATE A WARRANTY, OR IN ANY WAY INCREASE THE SCOPE OR DURATION OF THIS LIMITED WARRANTY.

## Limitation of Liability

IN NO EVENT SHALL SELLER BE LIABLE FOR ANY DIRECT, INDIRECT, SPECIAL, PUNITIVE, EXEMPLARY, OR CONSEQUENTIAL DAMAGES (INCLUDING, BUT NOT LIMITED TO, DAMAGE TO OR LOSS OF OTHER PROPERTY OR EQUIPMENT, BUSINESS INTERRUPTION, COST OF SUBSTITUTE PRODUCTS, LOSS OF TIME, LOSS PROFITS OR REVENUE, COST OF CAPITAL, LOSS OF USE, OR DIMINUTION IN VALUE) WHATSOEVER, AND SELLER'S LIABILITY, UNDER NO CIRCUMSTANCES, WILL EXCEED THE CONTRACT PRICE FOR THE GOODS AND/OR SERVICES FOR WHICH LIABILITY IS CLAIMED. ANY ACTION FOR BREACH OF CONTRACT BY YOU, OTHER THAN RIGHTS RESPECTING OUR LIMITED WARRANTY DESCRIBED ABOVE, MUST BE COMMENCED WITHIN 12 MONTHS AFTER THE DATE OF SALE.

## Sales and Service

For information about our worldwide locations, approvals, certifications and local representative:

Web site: [RedValve.com](http://RedValve.com) E-Mail: [support@redvalve.com](mailto:support@redvalve.com)



750 Holiday Drive, Suite 400, Pittsburgh, PA 15220 • Phone: 412-279-0044

*Red Valve Company reserves the right to incorporate our latest design and material changes without notice or obligation. Design features, materials of construction and dimensional data, as described in this manual, are provided for your information only and should not be relied upon unless confirmed in writing by Red Valve Company. Certified drawings are available upon request.*