

Series DX Knife Gate Valve

Installation, Operation and Maintenance Manual

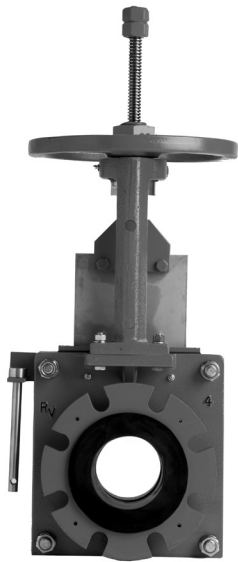

The Red Valve Series DX Slurry Knife Gate Valve is a 100% full bore, truly bi-directional valve designed for tough slurry applications. The DX features heavy-duty elastomer slurry sleeves which provide drop tight closure and are field replaceable, for ease of maintenance.

The DX incorporates two slurry sleeves that create a bi-directional drop tight seal, eliminating the need for packing. The Series DX is designed to discharge process fluid when the valve has left the full open or full closed position.

A wiper blade mounted on top of the valve prevents external grit and debris from entering the valve body. The wiper blade also minimizes process leaking from the top.

DO NOT INSTALL THE SERIES DX VALVE ABOVE ELECTRICAL PANELS, PUMPS OR PEDESTRIAN WALK WAYS WITHOUT THE USE OF A SPLASH GUARD OR A PIPE-A-WAY SYSTEM. DEPENDING ON THE COMPOSITION AND CHARACTERISTICS OF THE PROCESS FLUID, THIS DISCHARGE CAN BE DANGEROUS, RESULTING IN MAJOR EQUIPMENT DAMAGE, SEVERE INJURY TO PERSONNEL, OR EVEN DEATH.

IMPORTANT

When your Red Valve order arrives, check the contents carefully to assure no damage or loss occurred in transit.

Please take a moment to review this manual. Before performing any maintenance on the valve be sure the pipeline has been de-pressurized. The improper installation or use of this product may result in personal injury, product failure, or reduced product life. Red Valve Co., Inc. can accept NO liability resulting from the improper use or installation of this product. If you have any questions or problems, please call the customer service department at (412) 279-0044. We appreciate your comments. And thank you for choosing Red Valve.

The bottom of the valve is open to atmosphere to allow automatic discharge of some process fluid each time the valve strokes. This discharge flushes away any accumulated solids and prevents the de-watering and build-up of solids, which might otherwise bind the valve and prevent complete seating. There is no discharge when the valve is in the fully open or fully closed position.

High temperature, toxic, explosive, combustible, oxidizing, corrosive, acidic, caustic, and similar process fluids require extraordinary consideration. Proper precautions must be taken to ensure any hazardous discharge is contained and safely disposed of. Slippery materials such as soap, oils, or even plain water, can present a slipping hazard, resulting in severe bodily injury and death. Regular cleaning of the discharge area should be conducted to ensure a clean and safe work environment.

The discharged process fluid must not be allowed to fall on electrical or mechanical equipment. If the discharged process fluid cannot be discharged to a drain or sump an optional cover plate with NPT connections is available to provide a means of diverting a major portion of the discharge to a remote location, or to the downstream piping itself, minimizing the amount of clean-up required.

INSTALLATION

1. Check the flange faces of the pipe for rough/damaged areas. Pipeline flanges must be flat faced (NOT raised face), properly spaced, and parallel to achieve a proper seal. The flat flange face should be serrated as shown in Figure 1 (2-12 inch valves) or Figure 2 (14-30 inch valves). DO NOT mate DX Valves directly to expansion joints, or other compressible flange connections, such as a rubber flange connection.

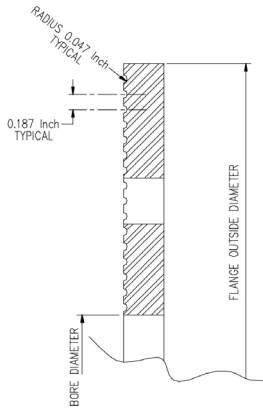

Figure 1 - Serrations for 2"-12" Flanges

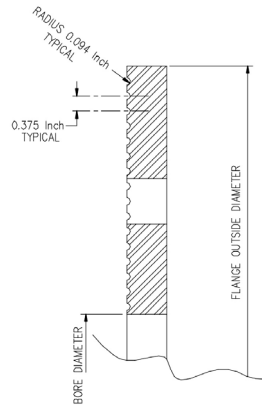

Figure 2 - Serrations for 4"-30" Flanges

The ID of the mating pipe flange must not exceed the nominal steel pipe OD by .12" for sizes 12" and smaller, or .25" for 14" and larger. Consult Red Valve if the flange ID exceeds these dimensions. Std slip-on steel flanges meet the criteria. Slip-on adapter flanges for ductile iron pipe will create a sealing problem.

The DX can be used for end of line service if a flat face flange is bolted to the downstream side so that the downstream seat is retained. When the DX is used to isolate equipment for future removal from the line, a spool piece needs to be installed between the valve and the equipment if the end of line condition will result upon removal of the equipment.

2. Separate flange gaskets are required on all valves with retaining rings. A metal serrated gasket is recommended when mating DX Valves with retaining rings to non-serrated steel, or PVC, FRP or any slick mating flange.
3. Actuate the valve to the full OPEN position for installation. The Red Valve DX Series of Knifegate Valves are properly lubricated prior to leaving the factory. If the factory lubrication has been either accidentally or intentionally removed, lubricate with Red Grease from Red Valve. NOTE: This material was previously known as Dow Corning Silicone Valve Lubricant & Sealant 111. No other lubricant is recommended for this purpose. See Section "LUBRICATION" for details.

4. INSTALLING FLANGE BOLTS:

CAUTION: Only use flange bolts of the correct length and in such manner that the BOLTS DO NOT BOTTOM OUT ON THE VALVE BODY. The use of bolts which are too long and bottom out can distort the body and cause permanent valve damage. Valve flanges with slots (vs. castings with round holes) should ALWAYS use washers under the bolt heads or nuts to better distribute the forces clamping the flanges together. Tighten all bolts uniformly, in a "star pattern" on both sides of the valve so as to distribute compression evenly on the slurry sleeves. Improper or uneven torquing of flange bolts can cause premature sleeve failure! It is important that there is enough flexibility in the mating pipe line to allow the pipeline flanges to move sufficiently to compress the valve flange gaskets. Piping that is hard mounted on both sides of the valve can prevent proper sealing and cause flange leakage. If necessary use an expansion joint or dresser coupling to allow sufficient movement.

5. Standard retainer ring material is UHMW. Valves 10" and larger are shipped with retainer rings mounted to the valve. Retaining rings on valves 3" - 8" are optional. Refer to Figure 3.

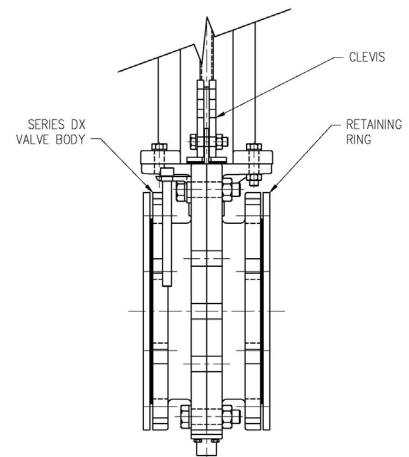

Figure 3

6. Regardless of valve size, installing Series DX in dead end service requires a retaining flange on the downstream flange. The retaining ring provided with the valve is not sufficient for dead end service. Refer to proper bolt size and torque requirements when installing a retainer flange.
7. Apply Red Grease from Red Valve liberally to the stem.
8. Fill out and attach the enclosed VALVE MAINTENANCE CARD to the valve. This has been provided for maintenance convenience.

NOTE: It is recommended that valves with actuators be installed in the vertical position. If actuated knife gates must be installed horizontally, it is recommended that the actuator be supported with a hanger or bracket.

NEVER...

Use bolts which bottom out in body.

DO...

Install with gate in open position.

DO...

Lubricate sleeves and gate.

DO...

Use flat faced flanges and tighten bolts evenly.

OPERATION

ACTUATORS:

All actuators are furnished completely assembled and fully operational. All valve accessories and instrumentation are properly set and calibrated at the Red Valve factory.

MANUAL ACTUATORS:

All handwheel, chainwheel, and bevel gear operators turn clockwise to close. The gate stops moving when the valve is fully opened or closed.

BEVEL GEAR:

Bevel gears operate the same as the standard handwheel. The handwheel is turned clockwise to close and counter clockwise to open.

CHAINWHEEL:

Chainwheels can be furnished on both standard valves and valves with bevel gears. The chain must be fed through the guides and over the spokes around the outside diameter of the rim. The ends of the chain are then joined with a connecting link.

ELECTRIC ACTUATORS:

Electric Actuators come completely operational, with limit and torque switches set. Please refer to the individual actuator manuals for additional operation or maintenance information.

LOCK OUT/TAG OUT:

Series DX Slurry Knife Gate Valves can be furnished with a lock out/tag out which is used to lock the gate in the fully open or fully closed position. Refer to valve technical information sheet regarding lockout/tagout recommendations and practices.

CYLINDER ACTUATORS :

Red Valve Cylinder Actuators operate from clean lubricated plant air. Cylinder actuators are available in three basic configurations: air-to-open / air-to- close, fail-safe open and fail-safe closed. Use of a pneumatic or electrical powered "spinner" to speed up operation of a manual operator may damage the operator. Consult the factory.

ATOO/ATC:

A single 4-way solenoid valve is used to operate this standard cylinder style. The "open" air supply is connected to the lower cylinder head, and the "close" air source is attached to the upper cylinder head. Each end of the cylinder must be vented when the other end of the cylinder is pressurized, in order for the cylinder to function.

FAIL-SAFE CLOSED:

A large diameter spring on the top of the cylinder piston provides the force to close this type of cylinder configuration. Air is only supplied to the BOTTOM cylinder head for valve opening. The top cylinder head must remain vented at all times. When the bottom of the cylinder is pressurized with plant air, the valve opens. The spring will close the valve automatically when the pressure is vented out of the bottom of the cylinder.

FAIL-SAFE OPEN:

A large diameter spring on the bottom of the cylinder piston provides the force to open this type of cylinder configuration. Air is only supplied to the top cylinder head for valve closing. The bottom cylinder head must remain vented at all times. When top of cylinder is pressurized with plant air, the valve closes. The spring will open the valve automatically when pressure is vented out through top of cylinder.

CAUTION:

Fail-safe cylinders contain large diameter springs in a compressed state. To avoid risk of serious injury, never attempt to disassemble fail-safe cylinders, NEVER cut, bend, or alter the protruding threads at the top or bottom of the cylinder. Fail-safe cylinders will actuate AUTOMATICALLY with an interruption of supply air. To avoid risk of injury from unexpected actuation, always relieve the cylinder supply air prior to inspecting, lubricating, or servicing the valve.

WATER HAMMER EFFECT:

Too rapid of closure of any valve can create a forceful and potentially damaging water hammer effect. To minimize the risk of water hammer related damage, Red Valve Company recommends that the closure rate of the valve be controlled by restricting the exhaust rate of cylinder pressure. The addition of a needle valve having a reverse flow check in the cylinder head ports will enable you to smoothly control closure rate. Install so that air is free flow into the cylinder and controlled when exhausted.

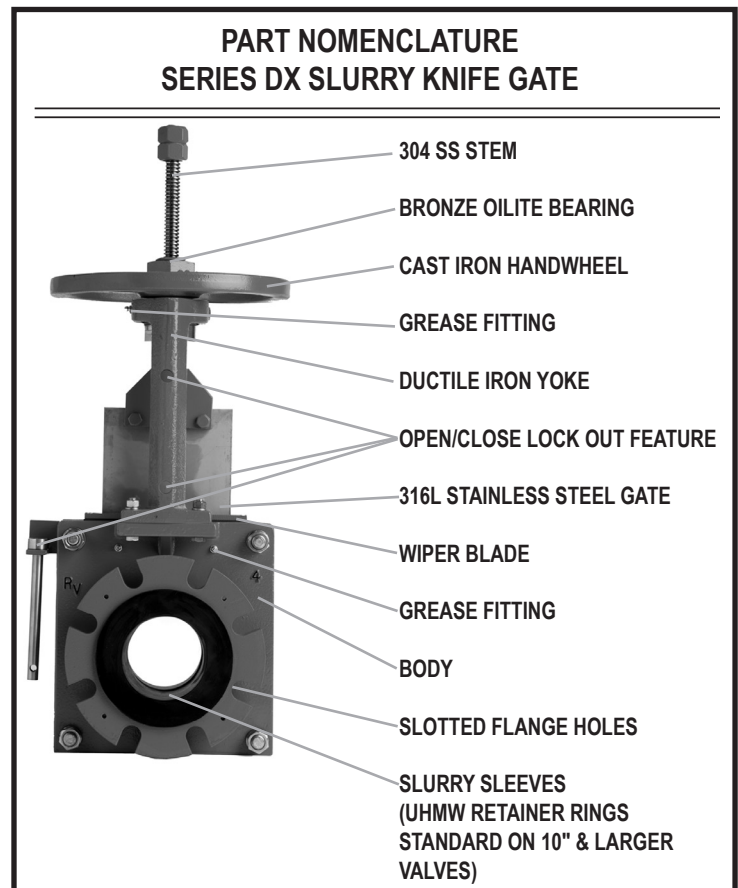

MAINTENANCE

1. Open the valve to the full open position.
2. Inspect both sides of the gate for excessive wear or pitting. Remove any dirt, debris, or caked material from the surfaces of the gate.
3. Apply a liberal amount of Red Valve's Red Grease to both sides of the gate. Red Valve's Red Grease is specifically formulated to provide proper lubrication and seating
4. Stroke the valve several to allow the lubricant to work into the valve.
5. Open the valve to the full open position and reapply Red Valve's Red Grease to both sides of the gate.
6. Using a grease gun, inject Red Valve's Red Grease into the chest area using the grease fitting located on both sides of the valve.
7. Return valve to service.

SLURRY SEAT REPLACEMENT:

1. Make sure there is no pressure in the pipeline. Follow all lockout procedures.
2. Remove the valve out of the line.
3. Lightly lubricate and replace the slurry sleeves and install the valve as described under installation.

STORAGE

If your Series DX Slurry Knife Gate Valve is to be stored for a period of time prior to installation, the following storage guidelines will help preserve your valve and assure a trouble free installation.

1. Store resilient slurry seats in a clean, cool and dry location. Avoid exposure to light, electric motors, dirt or chemicals.
2. Store valve in a clean, dry location. Make certain that valve and actuator are well supported. Do not stack other items on valve.
3. Grease stem, gate, and flange holes liberally to inhibit corrosion.

MAKE CERTAIN THAT SLURRY SLEEVES, AND THIS MANUAL ARE STORED AND READILY AVAILABLE AT TIME OF INSTALLATION.

TROUBLESHOOTING GUIDE

SYMPTOM:

VALVE BINDS or DIFFICULTY TURNING HANDWHEEL

- Examine stem and bushing for burrs or wear.
- Clean build-up on gate, flush body.
- Lubricate stem and gate.
- Remove slurry sleeves and inspect for damage.
- Make certain no in line obstructions exist.

SYMPTOM:

VALVE DOES NOT CHECK FLOW WHEN CLOSED

- Check for obstruction in line.
- Inspect gate and sleeves for build-up, wear, or damage.

SYMPTOM:

SLURRY SLEEVES ARE SOFTENED OR DETERIORATED

- Consult Red Valve for chemical compatibility of resilient seat cartridges (slurry seats).

INSTALLATION, OPERATION & MAINTENANCE SUPPLEMENT

NOMINAL VALVE SIZE	MAXIMUM OPERATING PRESSURE (PSI)		WEIGHT (LBS)	FACE TO FACE DIMENSIONS		RETAINING FLANGE THICKNESS (INCHES) (EACH SIDE)	BOLTING DATA						
	316SS GATE	17-4 PH GATE		FACE TO FACE WITHOUT COMPRESSION (INCHES)	FACE TO FACE WITH COMPRESSION (INCHES)		BOLTS PER VALVE	BOLT SIZE	FOR STEEL & CAST IRON FLANGES		FOR FRP & HDPE FLANGES		
									MINIMUM BOLT TORQUE (FT-LBS)	MAXIMUM BOLT TORQUE (FT-LBS)	MINIMUM BOLT TORQUE (FT-LBS)	MAXIMUM BOLT TORQUE (FT-LBS)	
VALVES WITHOUT RETAINING FLANGES													
3"	100	150	49	6.39	5.50	N/A	8	5/8-11	58	116	58	88	
4"	100	150	66	6.50	5.60	N/A	16	5/8-11	58	116	58	88	
6"	100	150	109	6.63	6.10	N/A	16	3/4-10	58	116	58	88	
8"	100	150	173	7.10	6.50	N/A	16	3/4-10	58	116	58	88	
VALVES WITH RETAINING FLANGES													
3"	100	150	49	7.14	6.25	0.38	8	5/8-11	58	116	58	88	
4"	100	150	66	7.25	6.35	0.38	16	5/8-11	58	116	58	88	
6"	100	150	109	7.38	6.85	0.38	16	3/4-10	58	116	58	88	
8"	100	150	173	7.85	7.25	0.38	16	3/4-10	58	116	58	88	
10"	100	150	222	9.38	8.65	0.38	24	7/8-9	58	116	58	88	
12"	100	150	340	10.70	9.90	0.38	24	7/8-9	58	116	58	88	
14"	100	150	495	11.38	10.48	0.38	24	1-8	75	150	75	114	
16"	100	150	635	12.63	11.63	0.38	32	1-8	140	280	140	210	
18"	100	150	895	13.35	12.05	0.38	32	1 1/8-7	140	280	140	210	
20"	100	150	1060	14.50	13.00	0.38	40	1 1/8-7	140	280	140	210	
24"	100	150	2250	15.57	13.82	0.38	40	1 1/4-7	180	360	180	270	
30"	75	150	2388	17.00	15.00	0.50	56	1 1/4-7	180	360	180	270	

Torque values are suggested minimum values.

Torque all flange bolts in a star pattern. First to 50% of tabulated values, then retorque to 100% of tabulated values. If greater torque is required, continue retorquing in increments of 50% of tabulated values.

Variables such as surface finish on bolt threads, type of anti-sieze compound used, and surface finish of the mating flanges all have an effect on the minimum torque required to obtain a leak tight flange seal.

Use of a high quality anti-sieze compound on all bolt threads is recommended.



Limited Warranty

Red Valve Company ("Seller") manufactured products, auxiliaries and parts thereof that we manufacture for a period of twenty-four (24) months from date of shipment from Seller's factory, are warranted to the original purchaser only against defective workmanship and material, but only if properly stored, installed, operated, and serviced in accordance with Seller's recommendations and instructions.

For items proven to be defective within the warranty period, your exclusive remedy under this limited warranty is repair or replacement of the defective item, at Seller's option, FCA Incoterms 2020 Seller's facility with removal, transportation, and installation at your cost.

Products or parts manufactured by others but furnished by Seller are not covered by this limited warranty. Seller may provide repair or replacement for other's products or parts only to the extent provided in and honored by the original manufacturer's warranty to Seller, in each case subject to the limitations contained in the original manufacturer's warranty.

No claim for transportation, labor, or special or consequential damages or any other loss, cost or damage is being provided in this limited warranty. You shall be solely responsible for determining suitability for use and in no event shall Seller be liable in this respect.

This limited warranty does not warrant that any Seller product or part is resistant to corrosion, erosion, abrasion or other sources of failure, nor does Seller warrant a minimum length of service.

Your failure to give written notice to us of any alleged defect under this warranty within twenty (20) days of its discovery, or attempts by someone other than Seller or its authorized representatives to remedy the alleged defects therein, or failure to return product or parts for repair or replacement as herein provided, or failure to store, install, or operate said products and parts according to the recommendations and instructions furnished by Seller shall be a waiver by you of all rights under this limited warranty.

This limited warranty is voided by any misuse, modification, abuse or alteration of Seller's product or part, accident, fire, flood or other Act of God, or your failure to pay entire contract price when due.

The foregoing limited warranty shall be null and void if, after shipment from our factory, the item is modified in any way or a component of another manufacturer, such as but not limited to; an actuator is attached to the item by anyone other than a Seller factory authorized service personnel.

All orders accepted shall be deemed accepted subject to this limited warranty, which shall be exclusive of any other or previous warranty, and this shall be the only effective guarantee or warranty binding on Seller, despite anything to the contrary contained in the purchase order or represented by any agent or employee of Seller in writing or otherwise, notwithstanding, including but not limited to implied warranties.

THE FOREGOING REPAIR AND REPLACEMENT LIMITED WARRANTY IS IN LIEU OF ALL OTHER WARRANTIES, OBLIGATIONS AND LIABILITIES, INCLUDING, BUT NOT LIMITED TO, ALL WARRANTIES OF FITNESS FOR A PARTICULAR PURPOSE OR OF MERCHANTABILITY OR OTHERWISE, EXPRESSED OR IMPLIED IN FACT OR BY LAW, AND STATE SELLER'S ENTIRE AND EXCLUSIVE LIABILITY AND YOUR EXCLUSIVE REMEDY FOR ANY CLAIM IN CONNECTION WITH THE SALE AND FURNISHING OF SERVICES, GOODS OR PARTS, THEIR DESIGN, SUITABILITY FOR USE, INSTALLATION OR OPERATIONS. NEITHER ANY PERFORMANCE OR OTHER CONDUCT, NOR ANY ORAL OR WRITTEN INFORMATION, STATEMENT, OR ADVICE PREPARED BY SELLER OR ANY OF OUR EMPLOYEES OR AGENTS WILL CREATE A WARRANTY, OR IN ANY WAY INCREASE THE SCOPE OR DURATION OF THIS LIMITED WARRANTY.

Limitation of Liability

IN NO EVENT SHALL SELLER BE LIABLE FOR ANY DIRECT, INDIRECT, SPECIAL, PUNITIVE, EXEMPLARY, OR CONSEQUENTIAL DAMAGES (INCLUDING, BUT NOT LIMITED TO, DAMAGE TO OR LOSS OF OTHER PROPERTY OR EQUIPMENT, BUSINESS INTERRUPTION, COST OF SUBSTITUTE PRODUCTS, LOSS OF TIME, LOSS PROFITS OR REVENUE, COST OF CAPITAL, LOSS OF USE, OR DIMINUTION IN VALUE) WHATSOEVER, AND SELLER'S LIABILITY, UNDER NO CIRCUMSTANCES, WILL EXCEED THE CONTRACT PRICE FOR THE GOODS AND/OR SERVICES FOR WHICH LIABILITY IS CLAIMED. ANY ACTION FOR BREACH OF CONTRACT BY YOU, OTHER THAN RIGHTS RESPECTING OUR LIMITED WARRANTY DESCRIBED ABOVE, MUST BE COMMENCED WITHIN 12 MONTHS AFTER THE DATE OF SALE.

Sales and Service

For information about our worldwide locations, approvals, certifications and local representative:

Web site: RedValve.com E-Mail: support@redvalve.com



750 Holiday Drive, Suite 400, Pittsburgh, PA 15220 • Phone: 412-279-0044

Red Valve Company reserves the right to incorporate our latest design and material changes without notice or obligation. Design features, materials of construction and dimensional data, as described in this manual, are provided for your information only and should not be relied upon unless confirmed in writing by Red Valve Company. Certified drawings are available upon request.