

Series 9000 Control Pinch Valve

Installation, Operation and Maintenance Manual



The Red Valve Series 9000 Pneumatically-Actuated Pinch Valve is a bi-directional valve designed for tough slurry applications. The elastomer sleeve closes on entrapped solids in the line. The flexing action of the sleeve breaks up any sediment or build-up in the valve, which makes the Series 9000 a reliable, low maintenance valve.

A variety of elastomers are available to suit your specific needs. Along with the standard Red Valve Sleeve, we offer Double Wall, Cone, and Variable Orifice Sleeves for special applications.

Series 9000 valves are constructed with 300# or 600# ANSI flanges.

- Simple design
- No Packing to maintain, ever
- Cost effective
- No cavities or dead spots to bind valve operation
- Low maintenance

IMPORTANT

Please take a moment to review this manual. Before performing any maintenance on the valve be sure the pipeline has been de-pressurized. The improper installation or use of this product may result in personal injury, product failure, or reduced product life. Red Valve Company, Inc. can accept NO liability resulting from the improper use or installation of this product. If you have any questions or problems, please call the customer service department at (412) 279-0044. We appreciate your comments. Thank you for choosing Red Valve.

GENERAL DESCRIPTION

The Red Valve Series 9000 High Pressure Pinch Valve consists of four major components:

1. Body - The body acts as a housing and support for the other valve components. It is not the primary pressure containing component.
2. Sleeve - The sleeve is the primary pressure containing component and is the only component in contact with the process fluid.
3. Mechanism - The pinching mechanism consists of a top and a bottom pinch bar with supports and carriers. The top pinch bar is connected to a pinch bar carrier connected to a stem.
4. Pneumatic Actuator - The actuator relies on hydraulic pressure within the cylinder to move a piston up or down. The stem is connected to the piston rod.

INSTALLATION

1. Series 9000 have standard ANSI B16.5 Class 300 or ANSI B16.1 Class 250 flanges. Due to clearances, the valves have tapped holes instead of through holes

CAUTION: Do not use bolts that are too long, as they will bottom out and crack the body. Stud bolts are recommended.

2. The flanges mating to the Series 9000 must be flat faced, not raised face, and serrated approximately 1/16" x 90°. Rubber will creep along smooth metal, PVC, or Teflon® flanges, eventually causing a leak. Flange I.D. should match the sleeve I.D. and should be free of sharp edges which could cut into sleeve flanges. Weld neck or socket weld flanges are recommended. Slip on or screw on flanges have a larger I.D. and can cut the rubber sleeve. If slip on or screw on flanges must be used, grind off all sharp I.D. edges.

3. Do not use sharp tools, such as screwdrivers or crow bars, on the rubber during installation. This can cut and damage the flange face and cause possible leakage.

4. The valve should be completely open before installing the valve in the pipeline or tightening the flange bolts. Tighten all flange bolts to values listed in the table on the back page. You will not over torque the flange rubber.

OPERATION AND ADJUSTMENT

The most critical factor for successful operation of the Series 9000 is using the correct amount of pneumatic pressure to operate the valve.

The amount of pressure required to close the valve depends on the pressure in the pipeline. Most cylinder operated valves require the full rated pneumatic pressure to open or close the valve. Operating the valve with less pressure may shorten the sleeve life, since velocities in a cracked open position are severe. If the valve is of a fail close design, insufficient pneumatic pressure may not allow the valve to fully open.

1. If flanges leak during operation, open the valve and retighten the flange bolts. Stroke the valve closed and then reopen and retighten the flange bolts. Do not clean the body end flange surfaces with rough abrasive wheels, as this will gouge the sealing surface and flange leakage will result.

2. If the valve leaks after installation, the leakage can be stopped by turning lower pinch bar adjusting bolts (14) three or four clockwise revolutions. Note: Loosen jam nuts before adjusting, and re-tighten after adjusting. Be sure to adjust each bolt an equal amount.

3. A spare sleeve and spare body gaskets should be placed on order when this valve is put in service.

PARTS — PNEUMATIC CYLINDER

- | | |
|----------------------------|--------------------------------------|
| 1. Actuator | 9. Lower Pinch Bar |
| 2. Mounting Plate | 10. Lower Pinch Bar Support |
| 3. Gasket | 11. Body Gaskets |
| 4. Body Bolts | 12. Body Bolts |
| 5. Body Top Half | 13. Body Bottom |
| 6. Sleeve | 14. Lower Pinch Bar Adjustment Bolts |
| 7. Upper Pinch Bar Carrier | |
| 8. Upper Pinch Bar | |

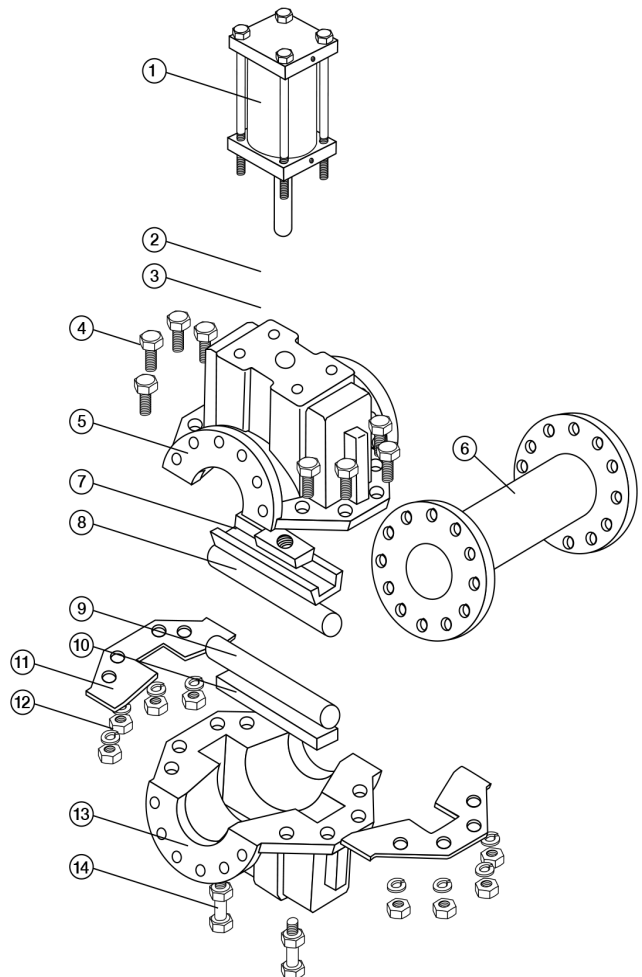

STORAGE

If your Series 9000 Pinch Valve is to be stored for a period of time prior to installation, the following guidelines will help preserve the valve and assure trouble-free installation.

1. Store valve and spare sleeves in a cool, clean, dry location.
2. Avoid exposure to light, electric motors, dirt, or chemicals
Resilient sleeves are subject to rapid deterioration when exposed to ozones and certain chemicals.
3. Grease flange threads liberally to inhibit rust or corrosion. Store valve in the full open position. Do not stack other items on top of the valve.
4. Store Installation Operation and Maintenance Manual with the valve so it will be readily available for installation.

DOUBLE WALL SLEEVES

Double Wall Sleeves have triple life expectancy on severe abrasion. The extra thickness requires the next larger flange size on the valve body.

It is recommended that the sleeve I.D. be the same as the pipe I.D. (Fig. 1) This will require that a reducing flange be purchased, or an oversize mating flange be installed on the pipe.

This is easily done by using blind flanges and boring the I.D. to suit the existing pipe. For example, on a 6" flange, 4" bore Double Wall valve, the mating flange would be a 6" blind flange bored out to slip over the 4" pipe (approximately 4-1/2" dia.). If it is not possible to match the pipe and sleeve I.D. as described above, the flanges will mate and the sleeve I.D. will protrude into the pipeline (Fig. 2). To prevent bulging and premature breaking of the Double Wall Sleeve, a steel washer must be installed as shown (Fig. 3). The steel washer should be 1/8" thick and be serrated on the side facing the sleeve. The washer O.D. can be just short of the bolt holes, or it can equal the flange O.D. and bolt holes can be drilled through the washer

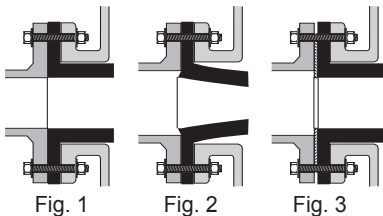

MISCELLANEOUS

Returns - All returns must have standard Red Valve Company return goods tags. Sleeves to be inspected by Red Valve Company must have the tag firmly attached to the sleeve via the bolt holes, and must list the company, order number, address, valve serial number, your telephone number, operating temperature, pressure, closing frequency, fluid media, and total days in service.

Important: If the product being returned has been in contact with a hazardous chemical or material, an MSDS (Material Safety Data Sheet) must be provided with the return paperwork; otherwise, the return will not be processed.

WASHER SIZING FOR SERIES 9000 VALVES

VALVE FLANGE SIZE	PORT SIZE	MINIMUM WASHER THICKNESS
1"	1/2"	1/4"
2"	1"	1/2"
3"	2"	1/2"
4"	3"	1/2"
6"	4"	1"
8"	6"	1"
10"	8"	1"
12"	10"	2"

MAINTENANCE

1. Inspection - The valve should occasionally be inspected for damage and wear. The inspection period should be determined by the severity of the service and environment. If the valve is periodically inspected and preventive maintenance done, the valve will last longer and operate better.

Caution: Do not remove any valve parts or bolting with pressure in the line. It is easy to inspect the valve for obvious problems.

2. Sleeve Replacement - **WARNING:** Be sure to flush all hazardous material and bleed all pressure from the pipeline before proceeding!

1. Open the valve completely – operate the cylinder to retract the piston rod.
2. Remove the valve from the pipeline.
3. Disassemble the body by removing the body bolts and remove the lower half of the body.
4. Remove the old sleeve by bending the flanges, and pulling the sleeve from the body casting. Remove the side body gaskets.
5. Place the new sleeve in the bottom casting and line up bolt holes. Be sure the flange bolt holes in the sleeve line up with the bolt holes in the body flange before bolting the two halves together. Note: For Cone and Variable Orifice Sleeves, be sure that the sleeve is oriented correctly with the flange marked "Inlet" on the upstream side of the valve, to insure proper operation of the valve. Place new side body gaskets. Do not reuse old side gaskets, as they have already been compressed and will not regain their original shape sufficiently to seal the body halves. Place top body components and install body bolts. Should it be necessary to adjust the upper pinch bar, use the stem adjuster between the cylinder piston and the valve stem. See attached supplemental instructions for details of adjustment.

PNEUMATIC ACTUATOR

1. DESCRIPTION

For pneumatically operated valves using a Red Valve supplied air cylinder actuator, the actuator is bolted to an actuator mounting frame. The frame is bolted to the top half of the valve body.

The pneumatic actuator contains a piston which is connected to the piston rod, which is used to operate the valve. Fail-closed and fail-open actuators contain a spring to return the piston to the end of stroke when all air pressure is removed. Double-acting actuators do not contain a spring. The piston rod passes through the bracket, and connects to the upper pinch bar via a stem adjustment unit. (Fig. C)

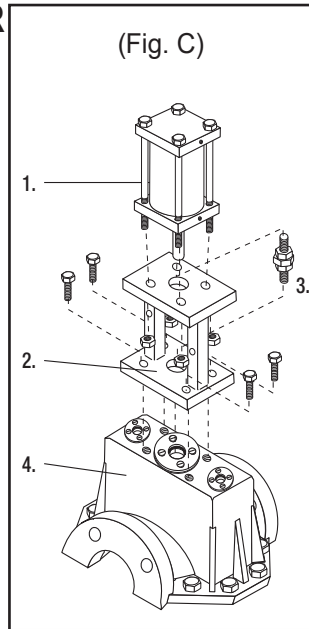

2. INSTALLATION

The valve must be fully open before installation. All valves are shipped from the factory in the full open position. Valves with fail-closed actuators are provided with a manual ball valve attached to the lower port of the cylinder. **DO NOT OPEN THIS VALVE.** The ball valve is used to trap air inside the cylinder to keep the spring compressed and the valve in the open position. The handle is removed for safety, and attached to the actuator, but only after the 9000 Valve is installed between flanges. After the valve is installed, **DO NOT REMOVE THE BALL VALVE.** Connect the operating handle and leave in the open position. The air connection must be made directly to the ball valve so that the valve can be trapped in the open position for removal.

3. OPERATION

All units are adjusted, tested, and inspected at the factory before shipment. Calibration and stroke adjustment may change during shipment. An operational test is recommended before installation in the pipeline.

To adjust the stroke, the upper bar can be adjusted using the stroke adjustment unit. (Fig. D) To lower the pinch bar, loosen both jamb nuts, and turn the adjustment mechanism counterclockwise.

To raise the pinch bar, turn clockwise. Re-tighten the jamb nuts after adjustment. The bottom pinch bar can be raised according to the directions provided in the IOM.

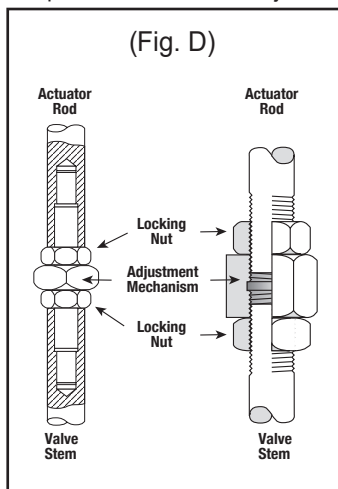

4. MAINTENANCE

A spare sleeve order should be placed when this valve is placed in service. A cylinder rebuild kit for the air cylinder actuator should also be ordered at the time the valve is placed in service. The actuator was lubricated during final assembly and testing at the factory, and does not need to be lubricated at start-up. The air cylinder actuator is self-lubricating and never requires lubrication.

5. REMOVAL & REFURBISHMENT DOUBLE-ACTING CYLINDER

Disassembly, refurbishment, reassembly, and testing of double-acting cylinders follows the same procedure for spring loaded actuators detailed below, except the there is no spring tension to relieve or re-compress.

SPRING LOADED ACTUATORS

Warning: spring actuators must be serviced with extreme caution. The springs are compressed and highly stressed. the top cylinder head or other parts can fly off and cause serious injury if the spring compression is not relieved properly.

1. The tie rods of spring compression loaded actuators are extra long to allow the spring compression to be relieved gradually. When disassembling the valve, **DO NOT** cut off the extra length of thread, even if it has become rusty or bent.

2. Remove all piping connected to the cylinder, and remove all accessory arms connected to the valve stem or piston rod.

3. Remove the four nuts on the tie rods below the actuator holding the cylinder to the mounting bracket. Separate the valve stem from the piston rod by loosening the jam nuts and unthreading the stem adjuster. Remove the actuator from the mounting bracket.

4. **DO NOT REMOVE ONE TIE ROD AT A TIME.** Turn one tie rod counterclockwise two or three turns, and then move to the next one. The compressed spring will push the cylinder heads apart, keeping tension on the tie rods. Slowly back off all 4 tie rods together, keeping the cylinder heads parallel. When the tie rods are completely unthreaded, the tension on the spring will be relieved.

5. Remove the piston and piston rod from the assembly. Remove the from bushing and seal from the bottom of the cylinder head. Clean out the tetra cord gasketing material from the cylinder groove in both cylinder heads. Do not use sharp tools, such as a screwdriver, which may scratch or damage the groove. Remove the O-ring from the groove in the piston.

6. Clean all parts thoroughly, including the inside of the cylinder tubing, of any foreign material. Inspect the sliding and sealing surfaces of all parts for nicks, scratches, and signs of wear. Check and inspect the bore of the cylinder for scratches, excessive wear, and any other defects that might prevent the piston O-ring from sealing properly. Inspect the piston rod for signs of wear, nicks, dents, scratches or any other condition that may damage the rod bearings or seals. In most cases a little polishing of the various parts will restore them to serviceable condition. Excessive wear on one side of the piston rod or bearing usually indicates misalignment and should be corrected.

7. Use new tetra cord, seals, and O-rings, available in the Red Valve Cylinder Rebuild Kit. Lubricate the new seals, O-rings, and inside wall of the cylinder using a silicone-based grease. The tetra cord does not need to be lubricated. Reassemble in reverse order of the above steps. Use care to prevent damage to the O-rings and seals. The rod threads should be coated with a high-quality anti-seize compound to allow tightening of the tie rods evenly for a proper pre-stressing of the spring.

8. Once the cylinder heads contact the spring, turn each tie rod only one or three turns at a time, keeping the cylinder heads parallel while compressing the spring.

9. After the cylinder head has been completely reassembled it should be tested, either on a test bench or installed on the valve. Check for rod seal leakage and cylinder head leakage as the piston is cycled at operating pressure.

REPLACING SLEEVE

1. To remove and replace the sleeve, the entire valve must be removed from the line. Be sure that the valve is in the full open position before removing the electrical supply or air supply. On fail-closed spring-loaded actuators, air must be trapped in the lower portion of the cylinder with the ball valve provided. See the supplementary sheet on installing valves with fail-closed cylinders for more information.

NOTE: The valve may need to be partially closed during this procedure. Actuators must have manual overrides, or access to the required air or electrical supply. If neither is available, the actuator must be removed. See the supplementary sheet for your type of actuator for more information.

2. Remove all body bolts, so that the valve body may be separated. Lift the top half, with actuator and mechanism, straight up to expose the sleeve.

3. Remove the screws that hold the lower tabs to the pinch bar, and the sleeve should move freely enough to allow access to the upper tabs one at a time. The actuator may need to be stroked closed to push the upper pinch bar farther out of the top body half.

4. The old sleeve is removed by bending one flange and sliding the sleeve through the mechanism.

5. The new sleeve is installed by bending one flange, sliding the sleeve through the mechanism, and attaching the tabs to the pinch bars. The top half can be lowered and re-attached to the bottom half. If provided, be sure that the rubber gasket is in place between the body halves and does not interfere with any bolt holes. Do not trim the gasket for length, it is necessary that the body gaskets extend beyond the serrated body casting flange.

6. The lower pinch bar may also be removed to make sleeve replacement easier. Remove the balance bars and side rod pins before lifting the top half of the body. Remove the screws that attach the tabs to the lower pinch bar, and slide the side rods down and out of the body. After replacing the sleeve and attaching the tabs to the upper pinch bar, lower the top half of the body, carefully guiding the side rods through the brass guides.

PARTS — PNEUMATIC CYLINDER

- | | |
|-------------------------|-----------------------|
| 1. Cylinder Top Head | 5. Seal Assembly |
| 2. Tie Rods | 6.* Spring |
| 3. Cylinder | 7.* Piston Stop |
| 4. Cylinder Bottom Head | 8. Piston with O-ring |
| | 9. Piston |

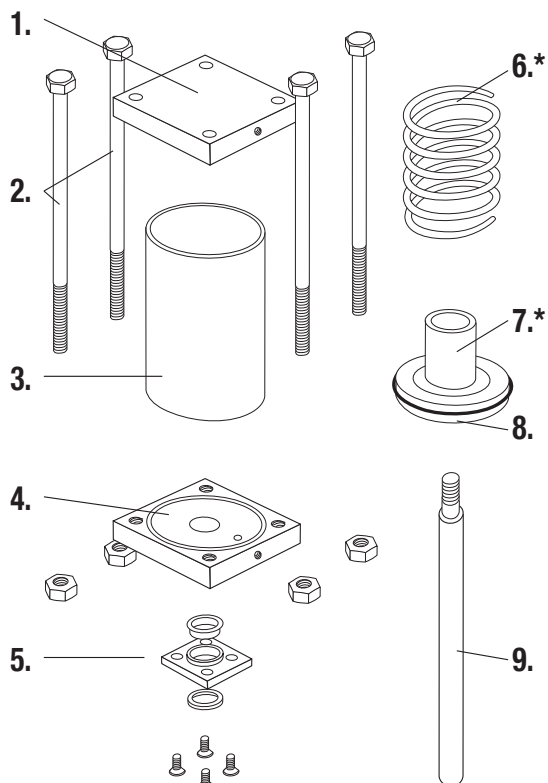

* Spring Return
Cylinders Only

SERIES 9000 FLANGE BOLTING SPECIFICATIONS

VALVE SIZE	NO. OF BOLTS	BOLT CIRCLE DIAMETER	THREAD SIZE	A	B	BOLT TORQUE (ft. lbs)	
						300 psi	720 psi
1"	4	3-1/2"	5/8" - 13 NC	3/4"	1"	55	130
2"	8	5"	5/8" - 13 NC	3/4"	1"	45	110
3"	8	6-5/8"	3/4" - 11 NC	1"	1-1/4"	85	205
4"	8	7-7/8"	3/4" - 11 NC	1"	1-3/8"	130	310
6"	12	10-5/8"	3/4" - 11 NC	1"	1-7/16"	115	270
8"	12	13"	7/8" - 11 NC	1"	1-5/8"	170	410
10"	16	15-1/4"	1" - 10 NC	1-1/4"	1-13/16"	180	430
12"	16	17-3/4"	1-1/8" - 10 NC	1-1/4"	2"	290	700

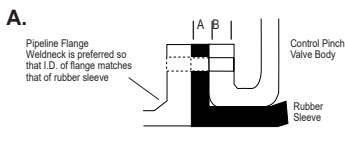

A. Standard pinch valves are built to schedule 40 pipe I.D. and to ANSI Class 125/150# flange and bolt circle specifications. It is recommended that the mating flanges are flat and full faced.

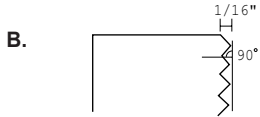

B. It is recommended that the mating flange be serrated to "grip" the rubber flange. The serrations should be cut 1/16" deep, with a 90 degree tool point. The pitch should be 8 (eight) cuts per inch.

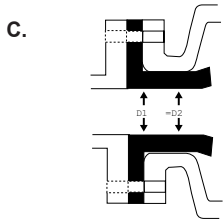

C. Mating flange ID must match the pinch valve sleeve ID.

D. When installing a pinch valve to a rubber, PVC, or any "slick" mating flange, we recommend that you install a metal serrated gasket between the two flanges to assist in the seal.

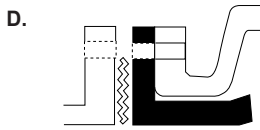

E. When bolting a pinch valve to a PVC or synthetic mating flange, use a split back-up retaining ring, since the mating flange will yield prior to generating enough force on the flange faces for a proper seal.

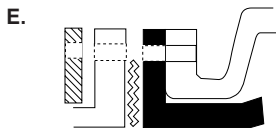

F. Torque all the flange bolts in a star pattern, first to 50% of tabulated values, then retorque to 100% of tabulated values. If greater torque is required, continue retorquing in increments of 50% of tabulated values. Use of high quality anti-seize compound on all bolt threads is recommended.

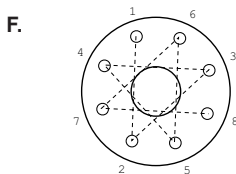

Variables such as the surface finish on bolt threads, type of anti-seize compound used, and surface finish of the mating flanges all have an effect on the minimum torque required to obtain a leak-tight flange seal.



Limited Warranty

Red Valve Company ("Seller") manufactured products, auxiliaries and parts thereof that we manufacture for a period of twenty-four (24) months from date of shipment from Seller's factory, are warranted to the original purchaser only against defective workmanship and material, but only if properly stored, installed, operated, and serviced in accordance with Seller's recommendations and instructions.

For items proven to be defective within the warranty period, your exclusive remedy under this limited warranty is repair or replacement of the defective item, at Seller's option, FCA Incoterms 2020 Seller's facility with removal, transportation, and installation at your cost.

Products or parts manufactured by others but furnished by Seller are not covered by this limited warranty. Seller may provide repair or replacement for other's products or parts only to the extent provided in and honored by the original manufacturer's warranty to Seller, in each case subject to the limitations contained in the original manufacturer's warranty.

No claim for transportation, labor, or special or consequential damages or any other loss, cost or damage is being provided in this limited warranty. You shall be solely responsible for determining suitability for use and in no event shall Seller be liable in this respect.

This limited warranty does not warrant that any Seller product or part is resistant to corrosion, erosion, abrasion or other sources of failure, nor does Seller warrant a minimum length of service.

Your failure to give written notice to us of any alleged defect under this warranty within twenty (20) days of its discovery, or attempts by someone other than Seller or its authorized representatives to remedy the alleged defects therein, or failure to return product or parts for repair or replacement as herein provided, or failure to store, install, or operate said products and parts according to the recommendations and instructions furnished by Seller shall be a waiver by you of all rights under this limited warranty.

This limited warranty is voided by any misuse, modification, abuse or alteration of Seller's product or part, accident, fire, flood or other Act of God, or your failure to pay entire contract price when due.

The foregoing limited warranty shall be null and void if, after shipment from our factory, the item is modified in any way or a component of another manufacturer, such as but not limited to; an actuator is attached to the item by anyone other than a Seller factory authorized service personnel.

All orders accepted shall be deemed accepted subject to this limited warranty, which shall be exclusive of any other or previous warranty, and this shall be the only effective guarantee or warranty binding on Seller, despite anything to the contrary contained in the purchase order or represented by any agent or employee of Seller in writing or otherwise, notwithstanding, including but not limited to implied warranties.

THE FOREGOING REPAIR AND REPLACEMENT LIMITED WARRANTY IS IN LIEU OF ALL OTHER WARRANTIES, OBLIGATIONS AND LIABILITIES, INCLUDING, BUT NOT LIMITED TO, ALL WARRANTIES OF FITNESS FOR A PARTICULAR PURPOSE OR OF MERCHANTABILITY OR OTHERWISE, EXPRESSED OR IMPLIED IN FACT OR BY LAW, AND STATE SELLER'S ENTIRE AND EXCLUSIVE LIABILITY AND YOUR EXCLUSIVE REMEDY FOR ANY CLAIM IN CONNECTION WITH THE SALE AND FURNISHING OF SERVICES, GOODS OR PARTS, THEIR DESIGN, SUITABILITY FOR USE, INSTALLATION OR OPERATIONS. NEITHER ANY PERFORMANCE OR OTHER CONDUCT, NOR ANY ORAL OR WRITTEN INFORMATION, STATEMENT, OR ADVICE PREPARED BY SELLER OR ANY OF OUR EMPLOYEES OR AGENTS WILL CREATE A WARRANTY, OR IN ANY WAY INCREASE THE SCOPE OR DURATION OF THIS LIMITED WARRANTY.

Limitation of Liability

IN NO EVENT SHALL SELLER BE LIABLE FOR ANY DIRECT, INDIRECT, SPECIAL, PUNITIVE, EXEMPLARY, OR CONSEQUENTIAL DAMAGES (INCLUDING, BUT NOT LIMITED TO, DAMAGE TO OR LOSS OF OTHER PROPERTY OR EQUIPMENT, BUSINESS INTERRUPTION, COST OF SUBSTITUTE PRODUCTS, LOSS OF TIME, LOSS PROFITS OR REVENUE, COST OF CAPITAL, LOSS OF USE, OR DIMINUTION IN VALUE) WHATSOEVER, AND SELLER'S LIABILITY, UNDER NO CIRCUMSTANCES, WILL EXCEED THE CONTRACT PRICE FOR THE GOODS AND/OR SERVICES FOR WHICH LIABILITY IS CLAIMED. ANY ACTION FOR BREACH OF CONTRACT BY YOU, OTHER THAN RIGHTS RESPECTING OUR LIMITED WARRANTY DESCRIBED ABOVE, MUST BE COMMENCED WITHIN 12 MONTHS AFTER THE DATE OF SALE.

Sales and Service

For information about our worldwide locations, approvals, certifications and local representative:

Web site: RedValve.com E-Mail: support@redvalve.com



750 Holiday Drive, Suite 400, Pittsburgh, PA 15220 • Phone: 412-279-0044

Red Valve Company reserves the right to incorporate our latest design and material changes without notice or obligation. Design features, materials of construction and dimensional data, as described in this manual, are provided for your information only and should not be relied upon unless confirmed in writing by Red Valve Company. Certified drawings are available upon request.