

# Series 5800 Control Pinch Valve

## Installation, Operation and Maintenance Manual

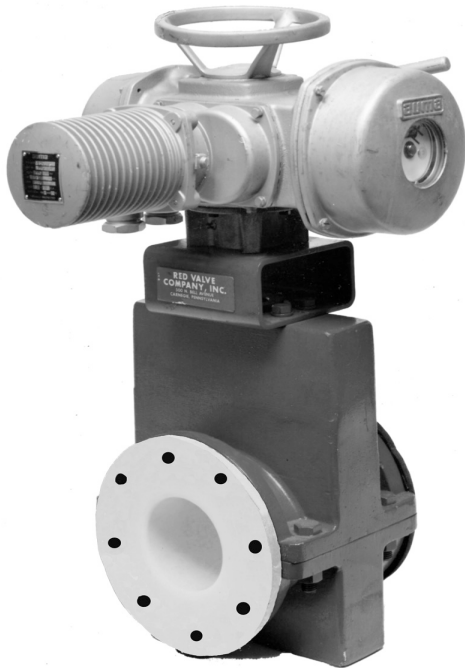

The Red Valve Series 5800 Electrically Actuated Control Pinch Valve is a bi-directional valve designed for tough slurry applications. The elastomer sleeve closes on entrapped solids in the line. The flexing action of the sleeve breaks up any sediment or build-up in the valve, which makes the Series 5800 a reliable, low maintenance valve.

A variety of elastomers are available to suit your specific needs. Along with the standard Red Valve sleeve, we offer Cone, Variable Orifice, Reduced Port, and Double Wall sleeves for special applications.

- Simple design
- No Packing to maintain, ever
- Cost effective
- No cavities or dead spots to bind valve operation
- Low maintenance

### IMPORTANT

Please take a moment to **review this manual**. Before performing any maintenance on the valve be sure that the pipeline has been depressurized. The improper installation or use of this product may result in personal injury, product failure, or reduced product life. Red Valve Co., Inc. can accept NO liability resulting from the improper use or installation of this product. If you have any questions or problems, please call the customer service hotline at (412) 279-0044. We appreciate your comments. And thank you for choosing Red Valve.

## GENERAL DESCRIPTION

The Red Valve Series 5800 Electrically Operated Control Pinch Valve consists of four major components:

1. **Body** The body acts as a housing and support for the other valve components. It is not the primary pressure containing component.
2. **Sleeve** The sleeve is the primary pressure containing component and is the only component in contact with the process fluid.
3. **Mechanism** Two mechanical pinch bars open and close the sleeve. The mechanism consists of a direct acting and (inner) reverse acting thread which, when rotated by the AUMA Actuator, opens and closes the sleeve on centerline.
4. **Electric Actuator** The electric actuator rotates a direct hex nut coupling (machined to match the mechanism stem) with an electric motor via reduction gears. It also has a de-clutchable handwheel override. The actuator is equipped with torque and limit switches to prevent damage by shutting off the actuator if torque or stroke limits are exceeded. For modulating applications, the actuator accepts the standard ISA 4-20 mA input signal.

## INSTALLATION

1. Series 5800 have standard ANSI B16.1 Class 125 flanges which are equivalent to ANSI B16.5 Class 150 flanges. Due to clearances, the valves may have tapped holes instead of through holes. **CAUTION:** Do not use bolts that are too long, as they may bottom out and crack the body. Stud bolts are recommended.
2. The flanges mating to the Series 5800 should be serrated approximately  $1/16$  " x  $90^\circ$ . Rubber will creep along smooth metal, PVC, or Teflon flanges, eventually causing a leak. Flange I.D. should match the sleeve I.D. and should be free of sharp edges which could cut into sleeve flanges. Weld neck or socket weld flanges are recommended. Slip on or screw on flanges have a larger I.D. and can cut the rubber sleeve. If slip on or screw on flanges must be used, grind off all sharp I.D. edges.
3. Do not use sharp tools, such as screwdrivers or crow bars, on the rubber during installation. This can cut and damage the flange face and cause possible leakage.
4. The valve should be completely open before installing the valve in the pipeline or tightening the flange bolts. Tighten all flange bolts to values listed in the table on the back page. You will not overtorque the flange rubber.
5. If flanges leak during operation, open the valve and retighten the flange bolts. Stroke the valve closed and then reopen and retighten the flange bolts.
6. Connect all electrical wiring as shown in the electric actuator manual included with these instructions.

## OPERATION AND ADJUSTMENT

1. Operate the handwheel override to close the valve approximately halfway. Energize the actuator to open the valve and observe if the valve opens or closes. If the valve is going in the wrong direction, the wiring from the power source is not connected properly. **STOP IMMEDIATELY!** See the electric actuation manual for details of corrective action.

If the direction of operation is correct, cycle the valve completely closed and completely open to verify smooth operation and complete stroking. The torque and limit switches and position indicator have been factory preset and normally do not need to be adjusted. If readjustment becomes necessary, follow the instructions in the electric actuator manual.

2. For both on-off and modulating valves, be certain the valve is closed completely and not cracked open in the closed position. Operating the valve in a cracked open position can shorten sleeve life, since flow velocities are very high under these conditions. For valves 4 " through 24 " , if the valve cannot be closed completely, the lower pinch bar can be raised by turning the adjusting nuts on the top of the guide rails clockwise. First, loosen the jam nuts, then turn the lower adjusting nut on each side rail one to two turns in the clockwise (tightening) direction. Be sure to turn each nut an equal amount. Check for complete closure of the valve. If necessary, repeat these steps until the valve seals completely. Finally, tighten the jam nuts, being careful not to disturb the setting of the adjusting nuts.
3. A spare sleeve should be placed on order when this valve is placed in service.

## MAINTENANCE

1. **Lubrication** The valve mechanism and actuator were completely lubricated during final assembly and testing at the factory, and do not need to be lubricated at start up. The valve should be lubricated every thirty days thereafter using a high quality lithium grease. Grease fittings are located as follows:
  - a. On the Electric Actuator (see Electric Actuator Manual)
  - b. In sizes up to 24 " , inside the top mounting bracket on the stem protectorIn addition, the stem protector on top of the actuator should be removed and the grease in the lower cavity around the stem should be replenished as needed.
2. **Sleeve Replacement WARNING:** Be sure to flush all hazardous material and bleed all pressure from the pipeline before proceeding!
  - a. Open the valve completely.
  - b. Remove the valve from the pipeline.
  - c. Disassemble the body by removing the body bolts and remove the lower half of the body.
  - d. Remove the old sleeve by unfastening the positive opening tabs, collapsing one flange, and pulling the sleeve through the mechanism.
  - e. Slide the new sleeve through the mechanism and repeat the above steps in reverse order. Be sure the flange bolt holes in the sleeve line up with the bolt holes in the body flange before bolting the two halves together.

**Note:** For Cone and Variable Orifice Sleeves, be sure that the sleeve is oriented correctly with the flange marked "Inlet" on the upstream side of the valve, to insure proper operation of the valve.

## MISCELLANEOUS

**Reduced Port** When replacing a Reduced Port sleeve in Series 5800 Valves, the pinching bars must be spaced at their original setting (Consult factory for details if this is not clear).

**Returns** All returns must have standard Red Valve Company return goods tags. Sleeves to be inspected by Red Valve Company must have the tag firmly attached to the sleeve via the bolt holes, and must list the company, order number, address, valve serial number, your telephone number, operating temperature, pressure, closing frequency, fluid media, and total days in service.

**Important:** If the product being returned has been in contact with a hazardous chemical or material, an MSDS (Material Safety Data Sheet) must be provided with the return paperwork; otherwise, the return will not be processed.

**DOUBLE WALL SLEEVES** have triple life expectancy on severe abrasion. The extra thickness requires the next larger flange size on the valve body. It is recommended that the sleeve I.D. be the same as the pipe I.D. (Fig. 1) This will require that a reducing flange be purchased, or an oversize mating flange be installed on the pipe. This is easily done by using blind flanges and boring the I.D. to suit the existing pipe. For example, on a 6 " flange, 4 " bore Double Wall valve, the mating flange would be a 6 " blind flange bored out to slip over the 4 " pipe (approximately 4-1/2 " dia.). If it is not possible to match the pipe and sleeve I.D. as described above, the flanges will mate and the sleeve I.D. will protrude into the pipeline (Fig. 2). To prevent bulging and premature breaking of the Double Wall Sleeve, a steel washer must be installed as shown (Fig. 3).

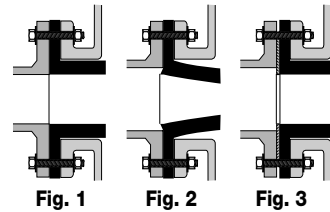

The steel washer should be 1/8 " thick and be serrated on the side facing the sleeve. The washer O.D. can be just short of the bolt holes, or it can equal the flange O.D. and bolt holes can be drilled through the washer.

## PARTS – Series 5800

1. Actuator
2. Mounting Bracket
3. Body Top
4. Pinching Mechanism
5. Sleeve
6. Body Bottom
7. Grease Fitting

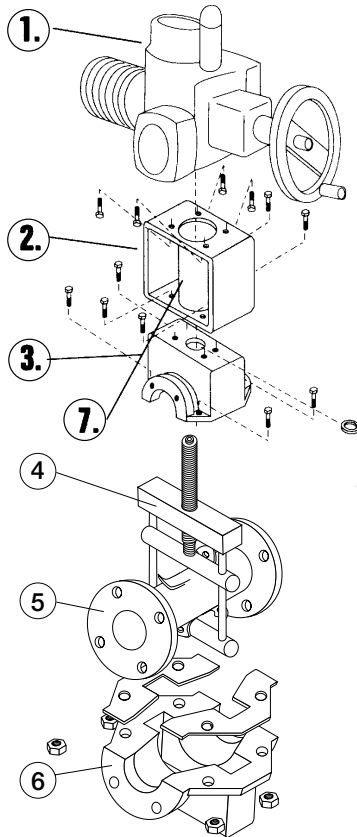

## STORAGE

If your Series 5800 Control Pinch Valve is to be stored for a period of time prior to installation, the following guidelines will help preserve the valve and assure trouble-free installation.

1. Store valve and spare sleeves in a cool, clean, dry location.
2. Avoid exposure to light, electric motors, dirt, or chemicals. Resilient sleeves are subject to rapid deterioration when exposed to ozones and certain chemicals.
3. Grease stem liberally and store valve in the full open position. Do not stack other items on top of the valve.
4. Store Installation Operation and Maintenance Manual with the valve so it will be readily available for installation.

## SERIES 5800 FLANGE BOLTING SPECIFICATIONS

VALVE SIZE	NO. OF BOLTS	BOLT CIRCLE DIAMETER	THREAD SIZE	L	A	B	C	BOLT TORQUE (ft. lbs)
1"	4	3-1/8"	1/2"- 13 NC	1-9/16"	1/2"	1/2"	9/16"	20
1-1/2"	4	3-7/8"	1/2"- 13 NC	1-7/8"	1/2"	11/16"	11/16"	30
2"	4	4-3/4"	5/8"- 11 NC	2"	1/2"	3/4"	3/4"	50
2-1/2"	4	5-1/2"	5/8"- 11 NC	2-1/4"	1/2"	7/8"	7/8"	60
3"	4	6"	5/8"- 11 NC	2-9/16"	3/4"	7/8"	15/16"	70
4"	8	7-1/2"	5/8"- 11 NC	2-11/16"	3/4"	1"	15/16"	50
5"	8	8-1/2"	3/4"- 10 NC	2-5/8"	3/4"	15/16"	15/16"	60
6"	8	9-1/2"	3/4"- 10 NC	3-1/8"	1"	1-1/8"	1"	80
8"	8	11-3/4"	3/4"- 10 NC	3-1/4"	1"	1-1/8"	1-1/8"	90
10"	12	14-1/4"	7/8"- 9 NC	3-3/8"	1"	1"	5/16"	70
12"	12	17"	7/8"- 9 NC	3-1/2"	1"	1-1/4"	1-1/4"	100
14"	12	18-3/4"	1"- 8 NC	3-3/4"	1"	1-3/8"	1-3/8"	100
16"	16	21-1/4"	1"- 8 NC	3-7/8"	1"	1-7/16"	1-7/16"	70
18"	16	22-3/4"	1-1/8"- 7 NC	4-11/16"	1-1/2"	1-5/8"	1-9/16"	90
20"	20	25"	1-1/8"- 7 NC	4-15/16"	1-1/2"	1-3/4"	1-11/16"	90
24"	20	29-1/2"	1-1/4"- 7 NC	5-3/8"	1-1/2"	2"	1-7/8"	110

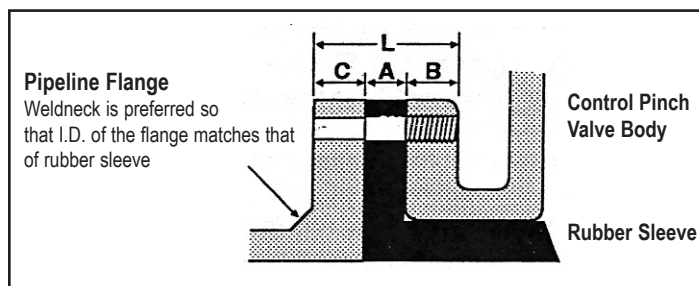

- Torque values are suggested minimum values
- Torque all flange bolts in a star pattern. First to 50% of tabulated values, then re-torque to 100% of tabulated values. If greater torque is required, continue re-torquing in increments of 50% of tabulated values.
- Variables such as surface finish on bolt threads, type of anti-seize compound used, and surface finish of the mating flanges and all have an effect on the minimum torque required to obtain a leak tight flange seal.
- Use of a high quality anti-seize compound on all bolt thread is recommended



## Limited Warranty

Red Valve Company ("Seller") manufactured products, auxiliaries and parts thereof that we manufacture for a period of twenty-four (24) months from date of shipment from Seller's factory, are warranted to the original purchaser only against defective workmanship and material, but only if properly stored, installed, operated, and serviced in accordance with Seller's recommendations and instructions.

For items proven to be defective within the warranty period, your exclusive remedy under this limited warranty is repair or replacement of the defective item, at Seller's option, FCA Incoterms 2020 Seller's facility with removal, transportation, and installation at your cost.

Products or parts manufactured by others but furnished by Seller are not covered by this limited warranty. Seller may provide repair or replacement for other's products or parts only to the extent provided in and honored by the original manufacturer's warranty to Seller, in each case subject to the limitations contained in the original manufacturer's warranty.

No claim for transportation, labor, or special or consequential damages or any other loss, cost or damage is being provided in this limited warranty. You shall be solely responsible for determining suitability for use and in no event shall Seller be liable in this respect.

This limited warranty does not warrant that any Seller product or part is resistant to corrosion, erosion, abrasion or other sources of failure, nor does Seller warrant a minimum length of service.

Your failure to give written notice to us of any alleged defect under this warranty within twenty (20) days of its discovery, or attempts by someone other than Seller or its authorized representatives to remedy the alleged defects therein, or failure to return product or parts for repair or replacement as herein provided, or failure to store, install, or operate said products and parts according to the recommendations and instructions furnished by Seller shall be a waiver by you of all rights under this limited warranty.

This limited warranty is voided by any misuse, modification, abuse or alteration of Seller's product or part, accident, fire, flood or other Act of God, or your failure to pay entire contract price when due.

The foregoing limited warranty shall be null and void if, after shipment from our factory, the item is modified in any way or a component of another manufacturer, such as but not limited to; an actuator is attached to the item by anyone other than a Seller factory authorized service personnel.

All orders accepted shall be deemed accepted subject to this limited warranty, which shall be exclusive of any other or previous warranty, and this shall be the only effective guarantee or warranty binding on Seller, despite anything to the contrary contained in the purchase order or represented by any agent or employee of Seller in writing or otherwise, notwithstanding, including but not limited to implied warranties.

THE FOREGOING REPAIR AND REPLACEMENT LIMITED WARRANTY IS IN LIEU OF ALL OTHER WARRANTIES, OBLIGATIONS AND LIABILITIES, INCLUDING, BUT NOT LIMITED TO, ALL WARRANTIES OF FITNESS FOR A PARTICULAR PURPOSE OR OF MERCHANTABILITY OR OTHERWISE, EXPRESSED OR IMPLIED IN FACT OR BY LAW, AND STATE SELLER'S ENTIRE AND EXCLUSIVE LIABILITY AND YOUR EXCLUSIVE REMEDY FOR ANY CLAIM IN CONNECTION WITH THE SALE AND FURNISHING OF SERVICES, GOODS OR PARTS, THEIR DESIGN, SUITABILITY FOR USE, INSTALLATION OR OPERATIONS. NEITHER ANY PERFORMANCE OR OTHER CONDUCT, NOR ANY ORAL OR WRITTEN INFORMATION, STATEMENT, OR ADVICE PREPARED BY SELLER OR ANY OF OUR EMPLOYEES OR AGENTS WILL CREATE A WARRANTY, OR IN ANY WAY INCREASE THE SCOPE OR DURATION OF THIS LIMITED WARRANTY.

## Limitation of Liability

IN NO EVENT SHALL SELLER BE LIABLE FOR ANY DIRECT, INDIRECT, SPECIAL, PUNITIVE, EXEMPLARY, OR CONSEQUENTIAL DAMAGES (INCLUDING, BUT NOT LIMITED TO, DAMAGE TO OR LOSS OF OTHER PROPERTY OR EQUIPMENT, BUSINESS INTERRUPTION, COST OF SUBSTITUTE PRODUCTS, LOSS OF TIME, LOSS PROFITS OR REVENUE, COST OF CAPITAL, LOSS OF USE, OR DIMINUTION IN VALUE) WHATSOEVER, AND SELLER'S LIABILITY, UNDER NO CIRCUMSTANCES, WILL EXCEED THE CONTRACT PRICE FOR THE GOODS AND/OR SERVICES FOR WHICH LIABILITY IS CLAIMED. ANY ACTION FOR BREACH OF CONTRACT BY YOU, OTHER THAN RIGHTS RESPECTING OUR LIMITED WARRANTY DESCRIBED ABOVE, MUST BE COMMENCED WITHIN 12 MONTHS AFTER THE DATE OF SALE.

## Sales and Service

For information about our worldwide locations, approvals, certifications and local representative:

Web site: [RedValve.com](http://RedValve.com) E-Mail: [support@redvalve.com](mailto:support@redvalve.com)



750 Holiday Drive, Suite 400, Pittsburgh, PA 15220 • Phone: 412-279-0044

*Red Valve Company reserves the right to incorporate our latest design and material changes without notice or obligation. Design features, materials of construction and dimensional data, as described in this manual, are provided for your information only and should not be relied upon unless confirmed in writing by Red Valve Company. Certified drawings are available upon request.*