

Redflex Rubber Expansion Joints Installation, Operation and Maintenance Manual



Red Valve's complete line of Redflex Expansion Joints, rubber pipe, and rubber fabricated products include single and multiple arched expansion joints with flanged or threaded end connections, concentric and eccentric reducers, rubber vibration pipe in flanged and slip-on models, and rubber fittings which are built to meet our customer's exact specifications. All Redflex products are available in a variety of elastomers to insure chemical compatibility with the fluid.

The Redflex product line is used in applications such as Wastewater treatment facilities, Power plants, Mining, Chemical plants, and Pulp and Paper mills. Redflex Expansion Joints and rubber fittings are manufactured in sizes up to 108".

IMPORTANT

Please take a moment to **review this manual**. **Before performing any maintenance on this product be sure the pipeline has been de-pressurized.** The improper installation or use of this product may result in personal injury, product failure, or reduced product life. Red Valve Co., Inc. can accept NO liability resulting from the improper use or installation of this product. If you have any questions or problems, please call the customer service department at (412) 279-0044. We appreciate your comments. Thank you for choosing Red Valve.

GENERAL DESCRIPTION

Redflex Expansion Joints are designed to alleviate stresses caused by thermal expansion and contraction in piping systems and reduces noise and vibration. The flexibility of these durable expansion joints permits the connecting of misaligned piping which is caused by worn parts, foundations settling or in the operating of systems and mechanical equipment.

Red Valve Company's Redflex Expansion Joints are manufactured like a heavy duty truck tire. The abrasive resistant, all elastomer expansion joints are designed for maximum flexibility and are available in sizes 1" - 108". Redflex Expansion Joints are reinforced with steel wire or solid steel reinforcing rings and synthetic fabric for additional strength.

The construction of the Redflex Expansion Joints includes: a tube, body cover, and flanges. The tube is a protective leakproof liner made of an elastomer, and is the only wetted part. The body consists of fabric and various rubber compounds and is reinforced with steel wire or rings for strength. The cover is formed from the desired elastomer, normally Neoprene or Butyl. The flanges are made of rubber constructions to resist stresses and provide a tight seal with the companion pipe flanges, eliminating the need for gaskets. The flanges are full face ANSI Class 125#.

ANCHORING

It is absolutely necessary that rigid metal pipe on both ends of the expansion joint or any flexible connector be properly anchored to eliminate the danger of excessive movement. It cannot be emphasized too strongly that rubber expansion joints and connectors, by virtue of their design and function, are not designed to take end thrusts and in all cases where such forces are likely to occur, proper anchoring is essential. Anchors should always be installed. An expansion joint should never be used to support the piping.

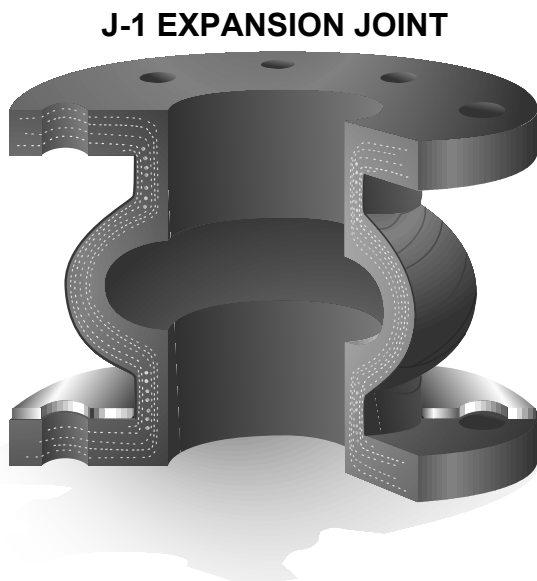

- NEVER** cut or modify Expansion Joint or rubber fitting.
- NEVER** operate rubber Expansion Joint or pipe above specified pressure and temperature rating.
- DO** keep Expansion Joints and rubber fittings on pallet until ready to install.
- DO** install expansion joints at recommended length, even if arch is slightly compressed.

STORAGE AND HANDLING

Red Valve Redflex Expansion Joints and rubber fittings should be stored in a cool, dry location on original shipping pallet or a wooden platform with the flanges down (Figure #1). Do not drop, bend or twist Redflex rubber products or damage may occur.

1. Do not allow joints to be in contact with the ground. If joint is to be stored outdoors, cover it with a tarpaulin to prevent weather and sun damage.
2. Avoid exposure to light, electric motors, dirt or chemi-cals. Redflex rubber products are subject to deterioration when exposed to ozones and non-compatible chemicals. Ozone especially causes age hardening of the elastomer.
3. Do not store other heavy items on top of an expansion joint.
4. Store Installation Operation Manual with product so it will be readily available for installation.
5. Do not lift joints or pipe by bolt holes. Tearing of the flange and bolt holes or deformation of the bolt holes can occur. They should be handled with a padded sling or a piece of pipe longer than the face-to-face of the joint with a cable through it so as not to cut into the rubber joint or pipe (Figure #2).

FIGURE 1

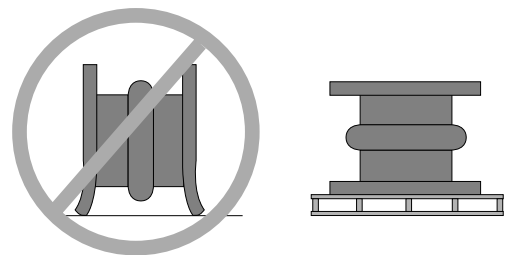
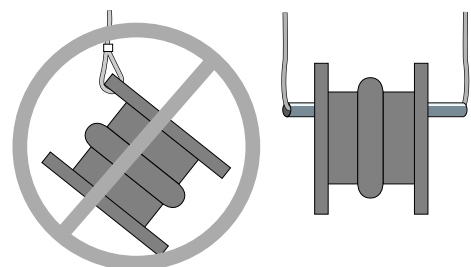

FIGURE 2



INSTALLATION INSTRUCTIONS REDFLEX EXPANSION JOINTS AND RUBBER FITTINGS

Review the application to which the expansion joint is going to be applied. Special attention should be paid to the pressure/vacuum, temperature, and movements to ensure that the expansion joint meets the system requirements.

1. INSPECT PIPE AND PRODUCT

Check flange faces of pipe and Redflex expansion joint for rough/damaged areas. Pipeline flanges must be flat, properly spaced, and parallel to achieve proper seal. Mating flange I.D. must match the Redflex I.D.. Flanges with an oversized I.D. can cut the Redflex flange. Grind or file any sharp edges of the pipeline flange to prevent damage to the Redflex expansion joint. Standard Redflex expansion joints are built to Schedule 40 pipe

I.D. and ANSI Class 125/150# flange and bolt circle specifications.

For slip-on joints and fittings, check that the I.D. of the joint or fitting is slightly larger than the O.D. of the mating pipe, and that the mating pipe edges are clean and free of sharp edges.

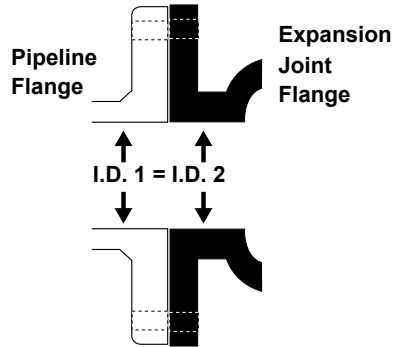

2. MEASURE LENGTH OF JOINT NEEDED

Measure the distance between the two flanges to be connected. Measurements should be taken at ambient temperature. Make sure that the flanges are properly aligned, and that any misalignment does not exceed 1/8".

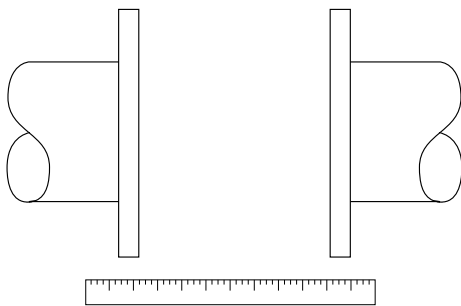

3. SET JOINT IN PLACE

Install Redflex in recommended face-to-face dimensions, avoiding expansion or elongation. Arch may be slightly compressed if distance between flanges necessitates. A thin film of graphite dispersed in water or glycerin may be applied to the face of the rubber flange before installing. This prevents the rubber from adhering to the metal flange so that if dismantling is ever necessary, the joint can be removed easily.

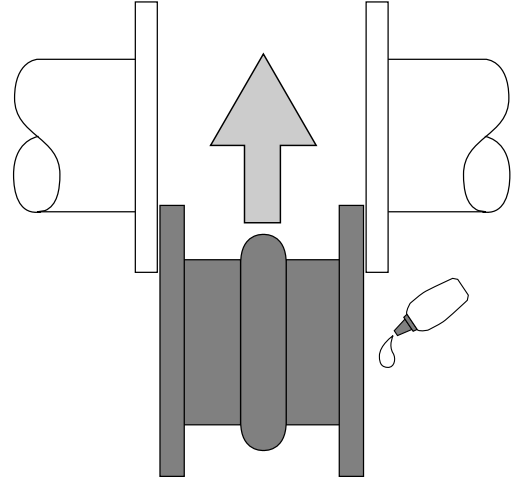

4. FOR RAISED FACE FLANGES

It is recommended that the mating flanges are flat and full-faced. Raised face mating flanges are not recommended. If installing to a raised faced flange, use a serrated ring gasket between the mating flange and the expansion joint flange.

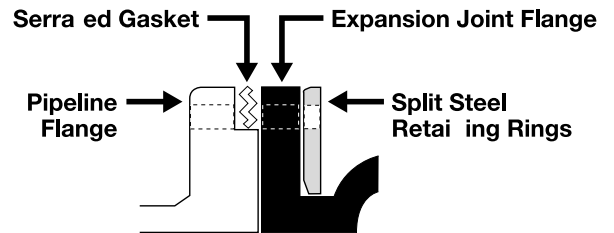

5. FOR NON-METALLIC FLANGES

When installing an expansion joint to a PVC or synthetic mating flange, use a split back-up retaining ring behind the PVC or synthetic flange. If this is not done, the mating flange will yield prior to generating enough force on the flange faces for a proper seal. It is recommended that a serrated metal gasket be installed between the PVC flange and the rubber expansion joint flange to insure proper sealing between the two.

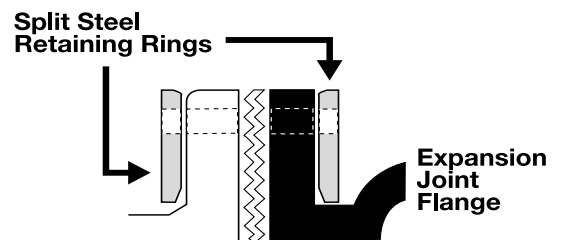

6. INSTALL THE RETAINING RINGS

One set of split steel back-up retaining rings is used for each flange of the expansion joint, to insure a tight, even seal and to prevent hardware from damaging the rubber flange. Bolts with integral washers should be inserted from the steel retaining ring side of the joint. Flat washers should be used in conjunction with hex bolts at all splits in the steel rings.

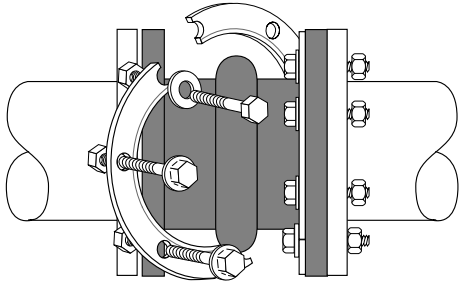

7. TIGHTENING BOLTS

When tightening bolts, two wrenches should be used to prevent damage to the rubber flange. Always use a star pattern when bolting an expansion joint or rubber pipe. Initially, torque the bolts to the recommended values shown in the Torque Values chart. Pressurize the line. Retorque the bolts to the proper torque. If process fluid leaks, increase the torque in increments of 50% of the tabulated values.

During installation you may need to retorque the flange bolts several times for a proper seal.

This will overcome any leaks due to the cold flow of the rubber expansion joint flange. Check bolt torque and retighten if necessary several days after initial operation and then periodically thereafter.

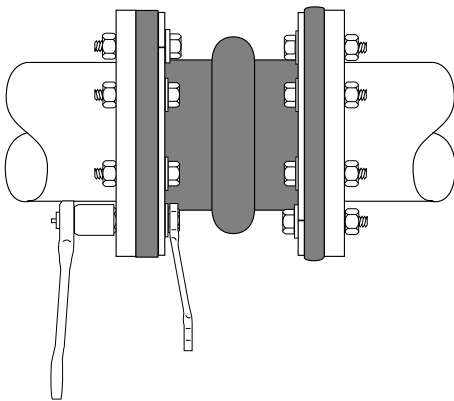
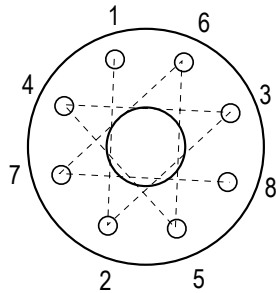

TORQUE VALUES

FLANGE SIZE (inches)	STANDARD PRESSURE		HIGH PRESSURE	
	PRESSURE RATING (PSI)	TORQUE (ft-pounds)	PRESSURE RATING (PSI)	TORQUE (ft-pounds)
1/2	165	13	200	16
3/4	165	25	200	30
1	165	20	200	25
1.25	165	25	200	30
1.5	165	25	200	30
2	165	40	200	50
2.5	165	55	200	65
3	165	60	200	75
4	165	40	200	50
5	140	45	190	60
6	140	55	190	75
8	140	75	190	100
10	140	70	190	95
12	140	105	190	142
14	85	80	130	125
16	65	55	110	90
18	65	70	110	120
20	65	70	110	115
24	65	90	100	135
30	55	65	90	110
36	55	90	90	145
42	55	109	80	150
48	55	100	80	150
54	55	125	80	185
66	55	160	80	230
72	45	145	70	225

8. INSPECT COVER AFTER INSTALLATION

After the unit is securely bolted into position, carefully inspect the cover of the expansion joint for any cuts or gouges caused by tools or bolts. These should be sealed with rubber cement to prevent oil or water from penetrating the elastomeric cover.

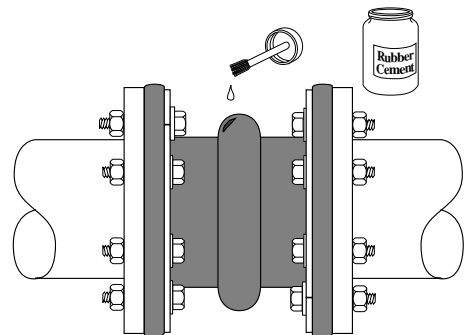

9. CONTROL UNITS

Control rods must be installed where piping is not sufficiently anchored to prevent excessive axial movement. Install the gusset plates first, to the pipeline flange.

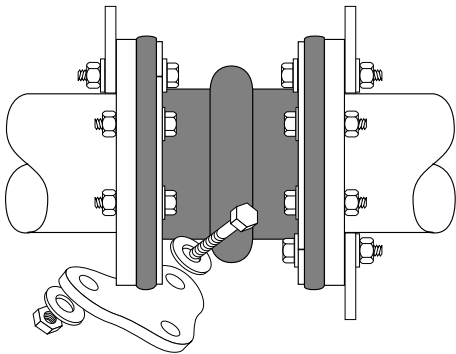

10. INSERTING THE CONTROL ROD

The control rod bolt is passed through holes in the gusset plates and secured using steel and rubber washers or rubber-backed steel washers to properly set the spacing of the rod. This rod limits the expansion of the joint to set limits.

When adjusting the control rod bolt take the following into consideration:

1. The free standing face-to-face dimension of the joint;
2. The required elongation capabilities of the joint;
3. The flange thicknesses of both mating flanges;
4. The thickness of the gusset plates;
5. Unless the joint is installed at the maximum elongated state (NOT RECOMMENDED), or you do not want the joint to elongate, the rod will be loose;
6. If you do not want the joint to elongate, adjust **HAND TIGHT ONLY**.

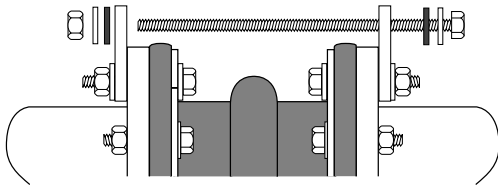

11. COMPRESSION SLEEVE

An optional compression sleeve can be used to limit the compression of the expansion joint. The control rod is passed through the sleeve before being inserted through the second gusset plate.

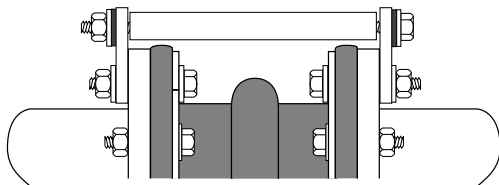

12. CONCENTRIC REDUCERS

If a reducing joint becomes necessary, it is recommended that the maximum reducing drop between the flanges should not exceed 10° or two pipe sizes. For concentric reducers and concentric reducing expansion joints, two different sized gusset plates are used, as shown. Installation is the same as for standard expansion joints, but use caution not to overtighten the control rod. Overtightening the control rod will cause the longer gusset plate to act as a lever and may bend the flange and/or plate.

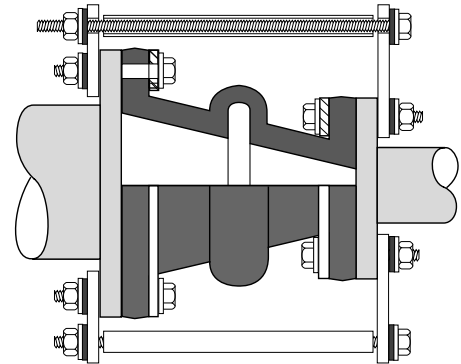

13. ECCENTRIC REDUCERS

When using eccentric reducers and eccentric reducing expansion joints, control rods and gusset plates can only be installed in one correct orientation for the flanges to mate. Use caution not to overtighten the control rod on the large gusset plate.

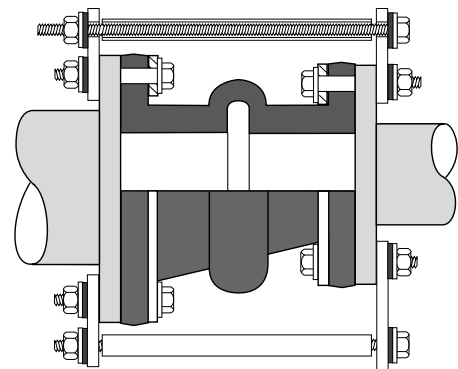

14. THREADED END EXPANSION JOINTS

For threaded end expansion joints, thread one end to pipe a few turns only. If pipe ends to be connected are misaligned, bend joint and begin to thread second coupling a few turns. Continue to thread both couplings, alternating sides every few turns until both are snug.

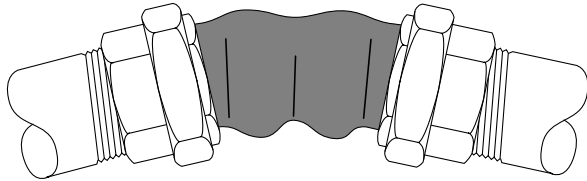

15A. INSTALLING SLIP-ON JOINT

Slide one end of the joint over one exposed pipe end. Be sure that the hose clamp is on the joint, but not tightened.

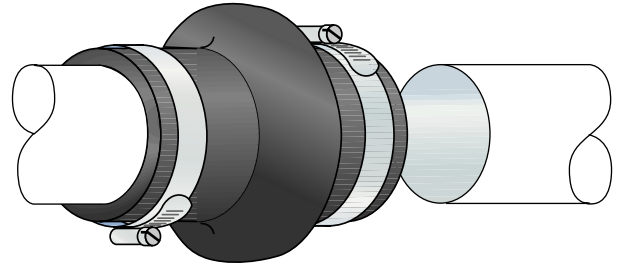

Slide the joint into place over the other pipe end and center the joint arch between the pipe ends. Make sure that the pipe is only inside the cuff area of the joint. Rotate the band clamps 180° from each other and tighten the band clamps securely.

15. SLIP-ON EXPANSION JOINTS

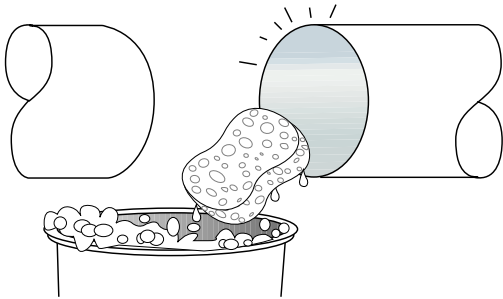

Be sure that ends of pipe are clean and free of oil or debris before installing slip-on style rubber expansion joints or pipe. Coarse sandpaper may be used to roughen the pipe surface to prevent the joint from slipping or rotating.

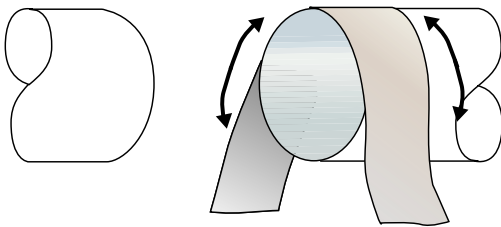

16. OTHER FITTINGS

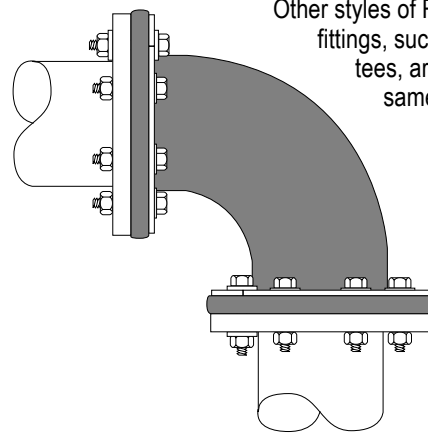

Other styles of Redflex rubber fittings, such as elbows and tees, are installed in the same way as expansion joints. The same cautions apply.

REFLEX CONTROL UNITS

Expansion Joints, Vibration Pipe, and Reducers installed in piping systems must be rigidly anchored on both sides of the unit to control expansion and contraction. The illustration below exhibits the details of a properly installed set of control units.

Control rods do not protect the expansion joint and piping system against lateral offsets and are not a replacement for proper system anchors, guides and supports.

Control rods should not be used with non-metallic flanges such as PVC, FRP and other flanges which do not have sufficient strength.

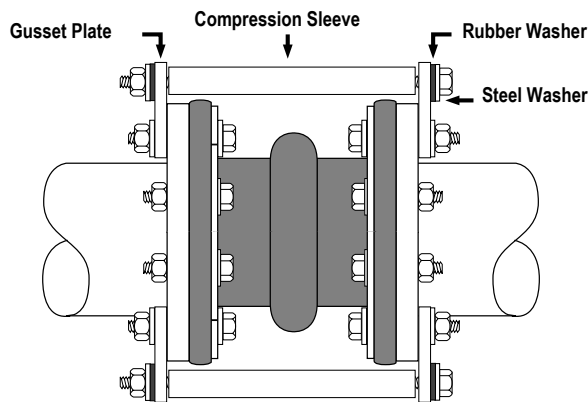

The table below indicates the number of rods to be used, by size and test pressure ratings. The calculation of the rods is based on an allowable stress of 65% of yield of the rod from ASTM A-307-68 steel.

CONTROL UNIT DIMENSIONS AND RATINGS

CONTROL UNIT			MAXIMUM SURGE OR TEST PRESSURE OF THE SYSTEMS				
NOMINAL PIPE SIZE EXP.JT. ID (inches)	PLATE THICKNESS (inches)	ROD DIAMETER (inches)	NUMBER OF CONTROL RODS RECOMMENDED				
			2	3	4	6	8
1	3/8	1/2	949	--	--	--	--
1-1/4	3/8	1/2	830	--	--	--	--
1-1/2	3/8	1/2	510	--	--	--	--
2	3/8	5/8	661	--	--	--	--
2-1/2	3/8	5/8	529	--	--	--	--
3	3/8	5/8	441	--	--	--	--
3-1/2	3/8	5/8	365	547	729	--	--
4	3/8	5/8	311	467	622	--	--
5	3/8	5/8	235	353	470	--	--
6	1/2	5/8	186	278	371	--	--
8	1/2	3/4	163	244	326	--	--
10	3/4	7/8	163	244	325	488	--
12	3/4	1	160	240	320	481	--
14	3/4	1	112	167	223	335	--
16	3/4	1-1/8	113	170	227	340	453
18	3/4	1-1/8	94	141	187	281	375
20	3/4	1-1/8	79	118	158	236	315
22	1	1-1/4	85	128	171	256	342
24	1	1-1/4	74	110	147	221	294
26	1	1-1/4	62	93	124	186	248
28	1-1/4	1-3/8	65	98	130	195	261
30	1-1/4	1-1/2	70	105	141	211	281
32	1-1/4	1-1/2	63	94	125	188	251
34	1-1/2	1-5/8	72	107	143	215	286
36	1-1/2	1-3/4	69	103	138	207	276
38	1-1/2	1-3/4	63	94	125	188	251
40	1-1/2	1-1/2	42	63	85	127	169
42	1-1/2	1-5/8	48	72	96	144	192
44	1-1/2	1-5/8	44	66	88	133	177
46	1-1/2	1-5/8	41	61	82	122	163
48	1-1/2	1-3/4	40	60	81	121	161
50	1-1/2	1-3/4	37	56	75	112	150
52	1-1/2	1-3/4	35	53	70	105	140
54	1-1/2	2	43	64	86	128	171
56	1-1/2	2	40	60	80	120	160
58	1-1/2	2	38	56	75	113	150
60	1-3/4	2	35	53	71	106	141
62	1-3/4	2	33	50	66	100	133
66	1-7/8	2	30	44	59	89	119
72	1-7/8	2	25	38	50	75	101
78	2	2-1/4	28	42	56	84	112
84	2-1/4	2-1/4	24	37	49	73	98
90	2-1/2	2-1/2	26	40	53	79	106
96	2-1/2	2-3/4	29	43	58	86	115
102	2-1/2	2-3/4	25	33	51	76	102
108	2-1/2	2-3/4	23	34	46	75	92
120	2-1/2	2-3/4	18	28	37	56	75
132	2-1/2	2-3/4	15	23	31	46	62
144	2-1/2	2-3/4	13	19	26	39	52

TROUBLESHOOTING

SYMPTOM: Flange leakage

- Check bolt tightness.
- Check mating flange surface area for grooves, scratches, or distorted areas.
- Overextension may indicate need for control units.

SYMPTOM: Cracking at base of arch and/or flange

- Check installed face-to-face dimensions for overextension or over compression.
- Check for proper pipe alignment to within 1/8".
- SYMPTOM:** Liquid weeping from bolt holes
- Check tube portion of joint for leaks. Replace joint or rubber fitting, if necessary.

SYMPTOM: Excessive ballooning of arch

- May indicate distortion or deterioration of joint strengthening members, or may indicate excessive system pressure.
- Reevaluate service conditions and install a new joint.

NEVER WELD NEAR REDFLEX EXPANSION JOINTS OR RUBBER FITTINGS!

Intense light and sparks from welding can damage the protective cover of rubber joints and fittings.

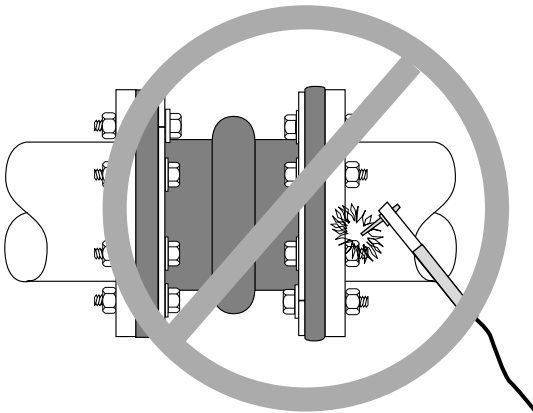

Limited Warranty

Red Valve Company ("Seller") manufactured products, auxiliaries and parts thereof that we manufacture for a period of twenty-four (24) months from date of shipment from Seller's factory, are warranted to the original purchaser only against defective workmanship and material, but only if properly stored, installed, operated, and serviced in accordance with Seller's recommendations and instructions.

For items proven to be defective within the warranty period, your exclusive remedy under this limited warranty is repair or replacement of the defective item, at Seller's option, FCA Incoterms 2020 Seller's facility with removal, transportation, and installation at your cost.

Products or parts manufactured by others but furnished by Seller are not covered by this limited warranty. Seller may provide repair or replacement for other's products or parts only to the extent provided in and honored by the original manufacturer's warranty to Seller, in each case subject to the limitations contained in the original manufacturer's warranty.

No claim for transportation, labor, or special or consequential damages or any other loss, cost or damage is being provided in this limited warranty. You shall be solely responsible for determining suitability for use and in no event shall Seller be liable in this respect.

This limited warranty does not warrant that any Seller product or part is resistant to corrosion, erosion, abrasion or other sources of failure, nor does Seller warrant a minimum length of service.

Your failure to give written notice to us of any alleged defect under this warranty within twenty (20) days of its discovery, or attempts by someone other than Seller or its authorized representatives to remedy the alleged defects therein, or failure to return product or parts for repair or replacement as herein provided, or failure to store, install, or operate said products and parts according to the recommendations and instructions furnished by Seller shall be a waiver by you of all rights under this limited warranty.

This limited warranty is voided by any misuse, modification, abuse or alteration of Seller's product or part, accident, fire, flood or other Act of God, or your failure to pay entire contract price when due.

The foregoing limited warranty shall be null and void if, after shipment from our factory, the item is modified in any way or a component of another manufacturer, such as but not limited to; an actuator is attached to the item by anyone other than a Seller factory authorized service personnel.

All orders accepted shall be deemed accepted subject to this limited warranty, which shall be exclusive of any other or previous warranty, and this shall be the only effective guarantee or warranty binding on Seller, despite anything to the contrary contained in the purchase order or represented by any agent or employee of Seller in writing or otherwise, notwithstanding, including but not limited to implied warranties.

THE FOREGOING REPAIR AND REPLACEMENT LIMITED WARRANTY IS IN LIEU OF ALL OTHER WARRANTIES, OBLIGATIONS AND LIABILITIES, INCLUDING, BUT NOT LIMITED TO, ALL WARRANTIES OF FITNESS FOR A PARTICULAR PURPOSE OR OF MERCHANTABILITY OR OTHERWISE, EXPRESSED OR IMPLIED IN FACT OR BY LAW, AND STATE SELLER'S ENTIRE AND EXCLUSIVE LIABILITY AND YOUR EXCLUSIVE REMEDY FOR ANY CLAIM IN CONNECTION WITH THE SALE AND FURNISHING OF SERVICES, GOODS OR PARTS, THEIR DESIGN, SUITABILITY FOR USE, INSTALLATION OR OPERATIONS. NEITHER ANY PERFORMANCE OR OTHER CONDUCT, NOR ANY ORAL OR WRITTEN INFORMATION, STATEMENT, OR ADVICE PREPARED BY SELLER OR ANY OF OUR EMPLOYEES OR AGENTS WILL CREATE A WARRANTY, OR IN ANY WAY INCREASE THE SCOPE OR DURATION OF THIS LIMITED WARRANTY.

Limitation of Liability

IN NO EVENT SHALL SELLER BE LIABLE FOR ANY DIRECT, INDIRECT, SPECIAL, PUNITIVE, EXEMPLARY, OR CONSEQUENTIAL DAMAGES (INCLUDING, BUT NOT LIMITED TO, DAMAGE TO OR LOSS OF OTHER PROPERTY OR EQUIPMENT, BUSINESS INTERRUPTION, COST OF SUBSTITUTE PRODUCTS, LOSS OF TIME, LOSS PROFITS OR REVENUE, COST OF CAPITAL, LOSS OF USE, OR DIMINUTION IN VALUE) WHATSOEVER, AND SELLER'S LIABILITY, UNDER NO CIRCUMSTANCES, WILL EXCEED THE CONTRACT PRICE FOR THE GOODS AND/OR SERVICES FOR WHICH LIABILITY IS CLAIMED. ANY ACTION FOR BREACH OF CONTRACT BY YOU, OTHER THAN RIGHTS RESPECTING OUR LIMITED WARRANTY DESCRIBED ABOVE, MUST BE COMMENCED WITHIN 12 MONTHS AFTER THE DATE OF SALE.

Sales and Service

For information about our worldwide locations, approvals, certifications and local representative:

Web site: RedValve.com E-Mail: support@redvalve.com



750 Holiday Drive, Suite 400, Pittsburgh, PA 15220 • Phone: 412-279-0044

Red Valve Company reserves the right to incorporate our latest design and material changes without notice or obligation. Design features, materials of construction and dimensional data, as described in this manual, are provided for your information only and should not be relied upon unless confirmed in writing by Red Valve Company. Certified drawings are available upon request.