



Materials of Construction

- ▶ Ductile Iron body 3" - 12"; cast iron body 14" - 30"; fabricated steel body 36" - 42"
- ▶ Standard sleeve materials: Pure Gum Rubber or EPDM, other materials available on request
- ▶ Standard gate: ASTM A240 T-316
- ▶ Optional gate: 17-4 pH, Hastelloy C or teflon-coated 316 SS

Series D Flexgate Manual

Red Valve's Series D Flexgate Valves are built with a cast or fabricated body and feature heavy-duty stainless steel gate. Ductile iron cast bodies provide enhanced performance where external and internal factors demand materials providing significant elongation. Removable rubber cartridge seats on either side of the gate provide a bi-directional seal and excellent wear resistance. The seats are metal-reinforced and available in a wide variety of elastomers for abrasion resistance and chemical compatibility. A port at the base of the valve allows for flushing.

The Flexgate Valve provides a bi-directional shutoff. A heavy-duty topworks is standard, and the relatively simple design eliminates expensive overhauls, unscheduled shutdowns and costly replacement parts – the only replacement parts are the slurry seats and packing.

Red Valve Flexgate Valves of 3" - 12" are provided with standard handwheel mechanisms featuring cast iron handwheels, machined 303 stainless steel stems with yoke sleeves and thrust washers designed to reduce operating torque. Flexgate Valves 14" and larger feature fabricated (tubular) handwheels. It is recommended that manual Flexgate Valves 12" and larger be specified with a 4:1 bevel gear actuator to reduce rim pull. Pneumatic and electric operators are available.

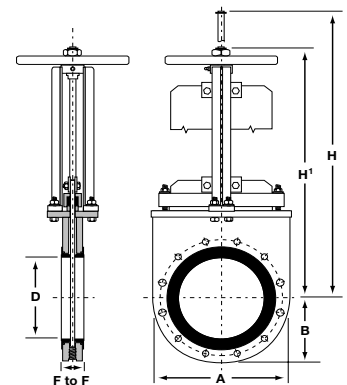

Series D Flexgate Manual

Valve Size D	Length F to F	Width A	Height B	Height Closed H'	Height Open H	Height Pneumatic Actuated	Gate Thickness	Max Working Pressure (psi)	
								Gate Material	
								316 SS	17-4 pH
3"	2.25"	8"	3.875"	17.125"	20.375"	27.5"	.25"	150	150
4"	2.25"	9.25"	4.75"	18.25"	22.625"	29.5"	.25"	150	150
6"	2.375"	11.5"	5.875"	21.0625"	27.1875"	33.5"	.5"	150	150
8"	2.875"	14"	7"	26.5625"	34.5625"	38.625"	.5"	150	150
10"	3.125"	16.75"	8.375"	32.4375"	43.625"	49.875"	.5"	150	150
12"	3.25"	20.125"	10.0625"	37"	50.875"	55"	.5"	100	150
14"	3.25"	21.5"	11"	43.625"	57.625"	59"	.5625"	100	150
16"	3.75"	24"	12.5"	47.5"	63"	63"	.675"	100	150
18"	3.75"	25.75"	13.25"	52.625"	70"	83.75"	.75"	100	150
20"	4.625"	27.5"	13.75"	57.9375"	74.125"	•	.875"	100	150
24"	4.75"	32.5"	16"	66.6875"	86.9375"	•	1"	100	150
30"	5"	38.75"	19"	88.625"	120.625"	•	1.125"	75	125
36"	5.125"	46"	23"	96"	134.875"	•	1.25"	75	125
42"	5.125"	53"	26.5"	100"	137.25"	•	1.25"	50	75

*Consult factory.

18" and smaller - installed length is .12" less than minimum F to F.

20" and larger - installed length is .25" less than minimum F to F.

48" and larger - consult factory.