

Series 48 Pressure Sensor

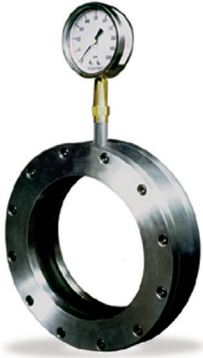

- Wafer design reduces costs
- Protects and isolates instrumentation
- Fits ASME 150 flanges
- Lightweight design
- Accommodates both positive and negative pressures

Materials of Construction

- **Body:** Carbon Steel, 316 Stainless Steel.
- **Sleeves:** Pure Gum Rubber (PGR), Ethylene Propylene Diene Terpolymer (EPDM)*, Acrylonitrile-Butadiene (NBR), Fluoroelastomer (FKM)*, Chloroprene (CR)*, Chlorosulfonated Polyethylene (CSM), Chloro-Isobutylene-Isoprene (CIIR).
* White food grade options available.
- **Flanges:** Carbon Steel, Stainless Steel or Polytetrafluoroethylene (PTFE)-Coated Carbon Steel.
- **Fill Fluids:** Silicone Oil (400° F), Ethylene Glycol and Water (200° F), Vegetable Oil (230° F).

Red Valve's Series 48 Pressure Sensor protects and isolates instrumentation, eliminating plugging and fouling that can occur in slurry and hard-to-gauge liquid applications. The economical Series 48 is designed to fit inside the bolt pattern of the pipe flanges, allowing for ease of installation and reducing the size of the unit.

Reliable, accurate instrument readings are often difficult or even impossible to obtain in pipelines carrying slurry, solids or chemical process. Standard diaphragm seals are vulnerable to plugging by debris or deposits and only give a pressure reading from one small area. With the Series 48 Pressure Sensor, these problems are eliminated.

The principle of operation is that line pressure is sensed through a flexible rubber sleeve which is a full 360° circumference of the pipe I.D. The captive fluid is displaced through the Series 48 Pressure Sensor body to the instrument's Bourdon Tube. All instrumentation is protected from the process which ensures accurate, repeatable readings.

SERIES 48

SIZE D	DIMENSIONS in/mm		WEIGHT lbs/kg
	OUTSIDE DIAMETER A	LENGTH F TO F	
2"	4.00	1.88	3
50mm	102mm	48mm	1
2.5"	4.5	1.88	5
65mm	114mm	48mm	2
3"	5.25	1.88	6
80mm	133mm	48mm	3
4"	6.75	2.13	9
100mm	171mm	54mm	4
6"	8.63	2.25	12
150mm	219mm	57mm	5
8"	10.88	642.50	16
200mm	276mm	mm	7
10"	13.25	2.75	22
250mm	337mm	70mm	10
12"	16.00	3.00	25
300mm	406mm	76mm	11
14"	17.63	3.00	50
350mm	448mm	76mm	23
16"	20.00	3.00	60
400mm	508mm	76mm	27
18"	21.50	3.00	70
450mm	546mm	76mm	32
20"	23.75	3.00	80
500mm	603mm	76mm	36
24"	28.13	3.0	115
600mm	715mm	76mm	52
30"	34.63	3.0	150
750mm	880mm	76mm	68
36"	41.13	4.0	248
900mm	1045mm	76mm	112
42"	47.13	4.0	319
1050mm	1197mm	76mm	145

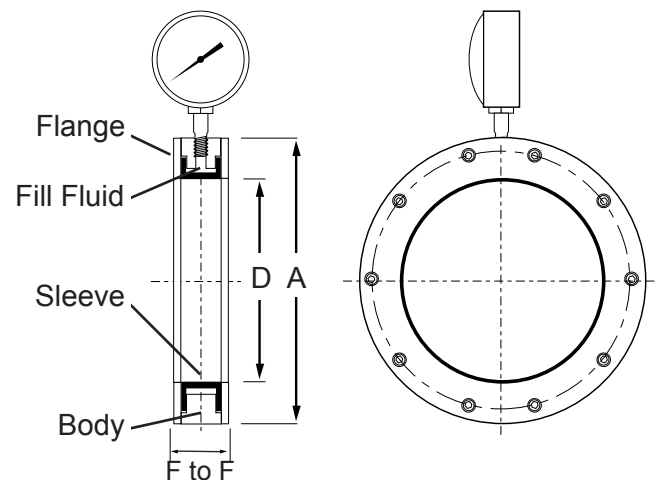

Product pressure ratings are consistent with the pressure ratings of the 150# flanges to which they are mated. Contact Red Valve for use with other flange classes.