

# PCV - Series 5700 Centerline Closure Control Pinch Valve

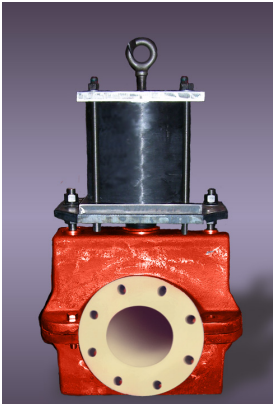

- Heavy-duty valve design closes on centerline.
- No packing to maintain, ever.
- Accurate, repeatable control.
- Ideal for corrosive and abrasive slurries.
- True feedback positioning.
- Bi-directional, drop-tight shutoff.

Red Valve's Series 5700 Control Pinch Valve is a cost-effective choice when centerline valve closure is required. The Series 5700 offers a 100% full round port opening and Class V shut-off. In throttling service, the 5700 provides true feedback positioning and accurate, repeatable and variable venturi flow control. There are no seats to grind, no stuffing box to repack and no packing gland to adjust ever. The rugged, self-cleaning elastomer sleeve isolates all mechanical parts of the mechanism, so the operating torque remains constant.

Full port opening and centerline closure is extremely important for larger-size pinch valves in abrasive and high-velocity applications. Patented by Red Valve in 1983, the Series 5700 with centerline closure outlasts all other types of gate, plug or ball valves on control of abrasive and corrosive slurries.

Cone Sleeves can be specified to further enhance control performance and match the exact Cv level desired. True feedback positioning is accomplished through the direct linkage of the pneumatic positioner to the valve stem shaft.

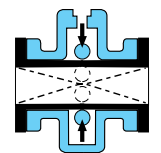

Closing Action

## Materials of Construction

- **Body:** Ductile iron
- **Sleeves:** Pure Gum Rubber, Ethylene Propylene Diene Terpolymer (EPDM)\*, Acrylonitrile-Butadiene (NBR), Fluoroelastomer (FKM)\*, Chloroprene (CR)\*, Chlorosulfonated Polyethylene (CSM), Chloro-Isobutylene-Isoprene (CIIR).
- \* - White food grade options available.
- **Drilled and tapped flanges:** ASME 150, ASME B16.1 125 cast flanges, AWWA C110 125 flanges, EN1092 PN 6, EN1092 PN 10, EN1092 PN 16, JIS 5K, JIS 10K. Other drill patterns available upon request.
- **Optional:** Extended stems and torque tubes, floorstands, control components.

## SERIES 5700

VALVE SIZE	DIMENSIONS in/mm				WORKING PRESSURE** psi/kPa	WEIGHT ATO/ATC lbs/kg
	LENGTH L	WIDTH W	HEIGHT			
			H	ATO/ATC H1*		
4.00" 100mm	9.00 229	10.50 267	5.75 146	33.00 838	150 1030	225 102
5.00" 125mm	10.00 254	15.38 391	8.50 216	36.00 914	150 1030	278 126
6.00" 150mm	10.50 267	18.25 464	7.88 200	36.00 914	150 1030	305 138
8.00" 200mm	16.00 406	23.25 591	9.13 232	43.50 1105	125 860	418 190
10.00" 250mm	20.00 508	29.75 756	10.50 267	48.00 1219	100 690	575 261
12.00" 300mm	24.00 610	35.00 889	11.50 292	56.00 1422	100 690	779 353
14.00" 350mm	28.00 711	37.50 953	14.50 368	58.75 1492	75 520	1450 658
16.00" 400mm	32.00 813	41.50 1054	15.50 394	64.50 1638	50 350	1810 821
18.00" 450mm	36.00 914	51.00 1295	17.00 432	68.50 1740	50 350	2160 980
20.00" 500mm	40.00 1016	47.75 1213	17.75 451	72.75 1848	50 350	2450 1111
24.00" 600mm	48.00 1219	57.00 1448	25.50 648	91.00 2311	50 350	4200 1905

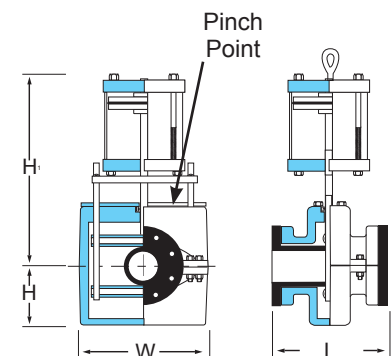

\* Consult factory for specific heights and weights of fail-close or fail-open valves.

\*\* Higher working pressures available.

For larger valve sizes up to 72"  
consult factory.