

Series 9000 High Pressure

- ▶ Working pressures up to 720 psi
- ▶ High-pressure pinch valve design for on/off applications
- ▶ Heavy-duty polyester or Kevlar®-reinforced high-pressure sleeve is the only wetted part
- ▶ Extended service life
- ▶ Sealed body design



The Series 9000 High-Pressure Control Pinch Valve is Red Valve's ANSI Class 300 pinch valve product. With Red Valve's Double-Wall Sleeve, the valve features increased abrasion resistance and can accommodate pressures up to 720 psi. The Series 9000 is also available with Red Valve's patented Cone Sleeve for control applications and the Standard Sleeve for lower pressure requirements.

A heavy-duty solid steel stroke adjustment unit located on the base of the Series 9000 allows the user to fine-tune control or adjust stroke for sleeve wear due to abrasion, reducing system downtime.

The Series 9000 is available with various actuators: bevel gear actuators for manual operation, hydraulic or electric actuators for automatic operation and pneumatic actuators for small or low-pressure applications.

For applications with low pressure requirements, the Series 9000 is also available in ANSI Class 150 drilling configurations.

Materials of Construction

- ▶ Ductile iron, 316 stainless steel bodies
- ▶ Sleeves available in Pure Gum Rubber, Neoprene, Hypalon®, Chlorobutyl, Buna-N, EPDM and Viton®
- ▶ Bevel Gear 4:1, 8:1, 16:1 actuator, electric actuator or hydraulic actuator
- ▶ Drilled and tapped to mate with ANSI B16.5 Class 300 flanges, ANSI B16.1 Class 250 flanges, optional Class 150 flanges

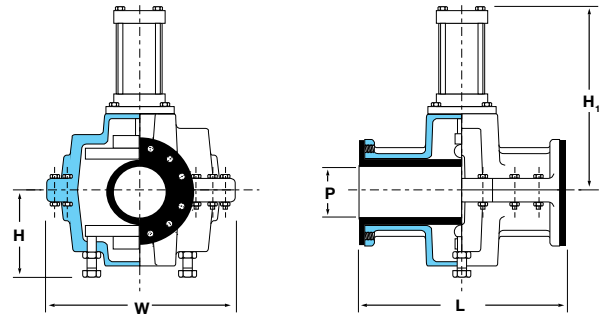

Dimensions Series 9000

VALVE SIZE	FULL - PORT SLEEVE		DOUBLE - WALL SLEEVE		LENGTH L	WIDTH W	HEIGHT		WEIGHT lbs
	PORT SIZE P	MAX WORKING PRESSURE AT 100°F psi *	PORT SIZE P	MAX WORKING PRESSURE AT 100°F psi *			H	H ₁ **	
1"	1"	720	1/2"	720	7-3/4"	12"	6"	16"	73
2"	2"	335	1-1/2"	720	9-1/2"	16"	8"	22"	229
3"	3"	240	2"	720	10-3/4"	17"	9"	26"	335
4"	4"	185	3"	720	14"	20"	11"	28"	438
6"	6"	245	4"	720	20"	23"	13"	33"	600
8"	8"	250	6"	720	26"	25"	15"	39"	802
10"	10"	200	8"	720	32-1/2"	33"	20"	51"	1,083
12"	12"	175	10"	720	38-1/2"	40"	25"	62"	1,477
14"	14"	320	12"	720	45"	45"	28"	68"	2,350
16"	16"	360	14"	720	51"	51"	31"	74"	3,500
18"	18"	265	16"	720	57-1/2"	56"	34"	80"	5,000
20"	20"	240	18"	720	64"	62"	37"	87"	6,850
24"	24"	250	20"	720	77"	71"	40"	100"	11,800
26"	26"	150	24"	720	83"	77"	43"	108"	15,000

*Higher working pressures available.

**With hydraulic cylinder.