



Red Valve Company, Inc.®

SERIES 5200E

Installation, Operation, and Maintenance Manual



The Red Valve Series 5200E Electrically Actuated Control Pinch Valve is a bi-directional valve designed for tough slurry applications. The elastomer sleeve closes on entrapped solids in the line. The flexing action of the sleeve breaks up any sediment or build-up in the valve, which makes the Series 5200E a reliable, low maintenance valve.

A variety of elastomers are available to suit your specific needs. Along with the standard Red Valve sleeve, we offer Cone, Variable Orifice, Reduced Port, and Double Wall sleeves for special applications.

- Simple design
- No Packing to maintain, ever
- Cost effective
- No cavities or dead spots to bind valve operation
- Low maintenance

IMPORTANT

Please take a moment to **review this manual**. **Before performing any maintenance on the valve be sure that the pipeline has been depressurized.** The improper installation or use of this product may result in personal injury, product failure, or reduced product life. Red Valve Co., Inc. can accept NO liability resulting from the improper use or installation of this product. If you have any questions or problems, please call the customer service hotline at (412) 279-0044. We appreciate your comments. And thank you for choosing Red Valve.

GENERAL DESCRIPTION

The Red Valve Series 5200E Electrically Operated Control Pinch Valve consists of four major components:

1. **Body** The body acts as a housing and support for the other valve components. It is not the primary pressure containing component.
2. **Sleeve** The sleeve is the primary pressure containing component and is the only component in contact with the process fluid.
3. **Mechanism** In sizes up to 3" and over 24", the mechanism consists of a top pinch bar connected to an ACME threaded stem. In sizes 4" and larger, the pinching mechanism consists of a top and a bottom pinch bar guided and supported by side rails. The top pinch bar is connected to an ACME threaded stem.
4. **Electric Actuator** The electric actuator rotates a bronze nut (threaded to match the mechanism stem) with an electric motor via reduction gears. It also has a de-clutchable handwheel override. The actuator is equipped with torque and limit switches to prevent damage by shutting off the actuator if torque or stroke limits are exceeded. For modulating applications, the actuator accepts the standard ISA 4-20 mA input signal.

INSTALLATION

1. Series 5200Es have standard ANSI B16.1 Class 125 flanges which are equivalent to ANSI B16.5 Class 150 flanges. Due to clearances, the valves may have tapped holes instead of through holes. **CAUTION:** Do not use bolts that are too long, as they may bottom out and crack the body. Stud bolts are recommended.
2. The flanges mating to the Series 5200E should be serrated approximately 1/16" x 90°. Rubber will creep along smooth metal, PVC, or Teflon flanges, eventually causing a leak. Flange I.D. should match the sleeve I.D. and should be free of sharp edges which could cut into sleeve flanges. Weld neck or socket weld flanges are recommended. Slip on or screw on flanges have a larger I.D. and can cut the rubber sleeve. If slip on or screw on flanges must be used, grind off all sharp I.D. edges.
3. Do not use sharp tools, such as screwdrivers or crow bars, on the rubber during installation. This can cut and damage the flange face and cause possible leakage.
4. The valve should be completely open before installing the valve in the pipeline or tightening the flange bolts. Valve sizes 10" and larger are "D-Ported" and have a pre-pinch at the bottom of the sleeve. Tighten all flange bolts to values listed in the table on the back page. You will not overtorque the flange rubber.
5. If flanges leak during operation, open the valve and retighten the flange bolts. Stroke the valve closed and then reopen and retighten the flange bolts.
6. Connect all electrical wiring as shown in the electric actuator manual included with these instructions.

OPERATION AND ADJUSTMENT

1. Operate the handwheel override to close the valve approximately halfway. Energize the actuator to open the valve and observe if the valve opens or closes. If the valve is going in the wrong direction, the wiring from the power source is not connected properly. **STOP IMMEDIATELY!** See the electric actuation manual for details of corrective action.

If the direction of operation is correct, cycle the valve completely closed and completely open to verify smooth operation and complete stroking. The torque and limit switches and position indicator have been factory preset and normally do not need to be adjusted. If readjustment becomes necessary, follow the instructions in the electric actuator manual.

2. For both on-off and modulating valves, be certain the valve is closed completely and not cracked open in the closed position.

Operating the valve in a cracked open position can shorten sleeve life, since flow velocities are very high under these conditions. For valves 4" through 24", if the valve cannot be closed completely, the lower pinch bar can be raised by turning the adjusting nuts on the top of the guide rails clockwise. First, loosen the jam nuts, then turn the lower adjusting nut on each side rail one to two turns in the clockwise (tightening) direction. Be sure to turn each nut an equal amount. Check for complete closure of the valve. If necessary, repeat these steps until the valve seals completely. Finally, tighten the jam nuts, being careful not to disturb the setting of the adjusting nuts.

3. A spare sleeve should be placed on order when this valve is placed in service.

PARTS – Series 5200E 3" and Under

1. Actuator
2. Mounting Bracket
3. Body Top
4. Pinching Mechanism
5. Sleeve
6. Body Bottom
7. Grease Fitting

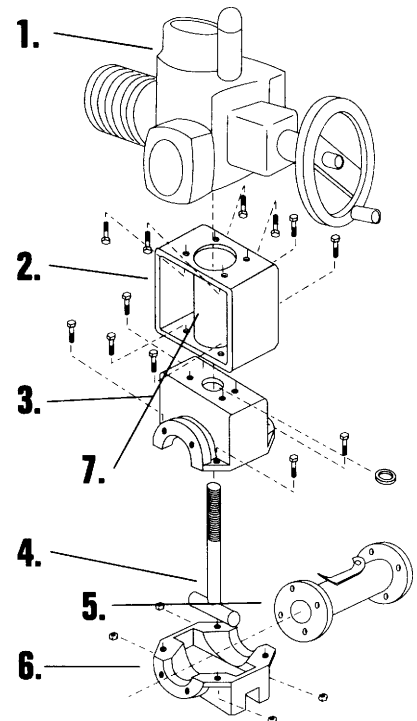

MAINTENANCE

1. **Lubrication** The valve mechanism and actuator were completely lubricated during final assembly and testing at the factory, and do not need to be lubricated at start-up. The valve should be lubricated every thirty days thereafter using a high quality lithium grease. Grease fittings are located as follows:

1. On the Electric Actuator (see Electric Actuator Manual)
2. In sizes up to 24", inside the top mounting bracket on the stem protector

In addition, the stem protector on top of the actuator should be removed and the grease in the lower cavity around the stem should be replenished as needed.

2. **Sleeve Replacement** **WARNING:** Be sure to flush all hazardous material and bleed all pressure from the pipeline before proceeding!

1. Open the valve completely. Valve sizes 10" and larger are "D-Ported" and have a pre-pinch at the bottom of the sleeve.
2. Remove the valve from the pipeline.
3. Disassemble the body by removing the body bolts and remove the lower half of the body.
4. Remove the old sleeve by unfastening the positive opening tabs, collapsing one flange, and pulling the sleeve through the mechanism.
5. Slide the new sleeve through the mechanism and repeat the above steps in reverse order. Be sure the flange bolt holes in the sleeve line up with the bolt holes in the body flange before bolting the two halves together.

Note: For Cone and Variable Orifice Sleeves, be sure that the sleeve is oriented correctly with the flange marked "Inlet" on the upstream side of the valve, to insure proper operation of the valve.

PARTS – Series 5200E 4" through 24"

1. Actuator
2. Mounting Bracket
3. Body Top
4. Pinching Mechanism
5. Sleeve
6. Body Bottom
7. Grease Fitting
8. Adjusting Nuts and Jam Nuts

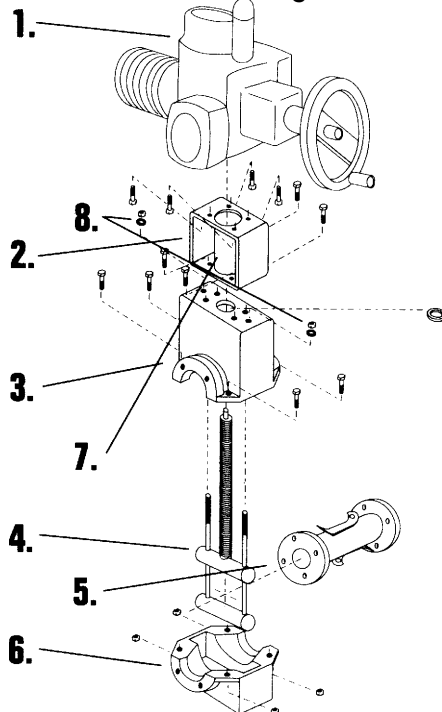

MISCELLANEOUS

Reduced Port or Pre-Pinched Valves When replacing either a Reduced Port or Pre-Pinched sleeve in Series 5200E Valves, the pinching bars must be spaced at their original setting (Consult factory for details if this is not clear).

Returns All returns must have standard Red Valve Company return goods tags. Sleeves to be inspected by Red Valve Company must have the tag firmly attached to the sleeve via the bolt holes, and must list the company, order number, address, valve serial number, your telephone number, operating temperature, pressure, closing frequency, fluid media, and total days in service.

Important: If the product being returned has been in contact with a hazardous chemical or material, an MSDS (Material Safety Data Sheet) must be provided with the return paperwork; otherwise, the return will not be processed.

DOUBLE WALL SLEEVES have triple life expectancy on severe abrasion. The extra thickness requires the next larger flange size on the valve body.

It is recommended that the sleeve I.D. be the same as the pipe I.D. (Fig. 1) This will require that a reducing flange be purchased, or an oversize mating flange be installed on the pipe. This is easily done by using blind flanges and boring the I.D. to suit the existing pipe. For example, on a 6" flange, 4" bore Double Wall valve, the mating flange would be a 6" blind flange bored out to slip over the 4" pipe (approximately 4-1/2" dia.).

If it is not possible to match the pipe and sleeve I.D. as described above, the flanges will mate and the sleeve I.D. will protrude into the pipeline (Fig. 2). To prevent bulging and

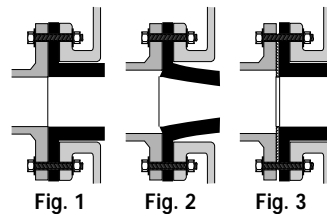

Fig. 1

Fig. 2

Fig. 3

premature breaking of the Double Wall Sleeve, a steel washer must be installed as shown (Fig. 3). The steel washer should be 1/8" thick and be serrated on the side facing the sleeve. The washer O.D. can be just

short of the bolt holes, or it can equal the flange O.D. and bolt holes can be drilled through the washer.

STORAGE

If your Series 5200E Control Pinch Valve is to be stored for a period of time prior to installation, the following guidelines will help preserve the valve and assure trouble-free installation.

1. Store valve and spare sleeves in a cool, clean, dry location.
2. Avoid exposure to light, electric motors, dirt, or chemicals. Resilient sleeves are subject to rapid deterioration when exposed to ozones and certain chemicals.
3. Grease stem liberally and store valve in the full open position. Do not stack other items on top of the valve.
4. Store Installation Operation and Maintenance Manual with the valve so it will be readily available for installation.

SERIES 5200E FLANGE BOLTING SPECIFICATIONS

VALVE SIZE	NO. OF BOLTS	BOLT CIRCLE DIAMETER	THREAD SIZE	A	B	BOLT TORQUE (ft. lbs)
1"	4	3-1/8"	1/2" - 13 NC	1/2"	3/4"	20
1-1/2"	4	3-7/8"	1/2" - 13 NC	1/2"	5/8"	25
2"	4	4-3/4"	5/8" - 11 NC	1/2"	3/4"	40
2-1/2"	4	5-1/2"	5/8" - 11 NC	1/2"	3/4"	50
3"	4	6"	5/8" - 11 NC	1/2"	3/4"	55
4"	8	7-1/2"	5/8" - 11 NC	3/8"	7/8"	40
5"	8	8-1/2"	3/4" - 10 NC	3/8"	-	50
6"	8	9-1/2"	3/4" - 10 NC	5/8"	7/8"	60
8"	8	11-3/4"	3/4" - 10 NC	1"	1"	70
10"	12	14-1/4"	7/8" - 9 NC	1/2"	1"	70
12"	12	17"	7/8" - 9 NC	5/8"	1-1/4"	75
14"	12	18-3/4"	1" - 8 NC	1"	1-3/8"	100
16"	16	21-1/4"	1" - 8 NC	1"	1-7/16"	70
18"	16	22-3/4"	1-1/8" - 7 NC	1-1/2"	1-5/8"	55
20"	20	25"	1-1/8" - 7 NC	1-1/2"	1-3/4"	50
24"	20	29-1/2"	1-1/4" - 7 NC	1-1/2"	2"	70

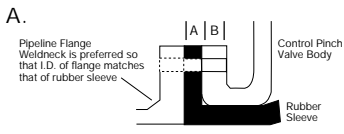

A. Standard pinch valves are built to schedule 40 pipe I.D. and to ANSI Class 125/150# flange and bolt circle specifications. It is recommended that the mating flanges are flat and full faced.



B. It is recommended that the mating flange be serrated to "grip" the rubber flange. The serrations should be cut 1/16" deep, with a 90 angle tool point. The pitch should be 8 (eight) cuts per inch.

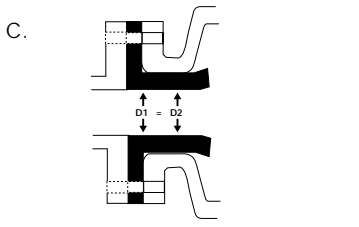

C. Mating flange ID must match the pinch valve sleeve ID.

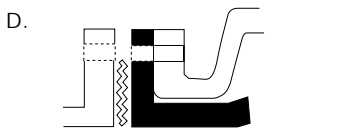

D. When installing a pinch valve to a rubber, PVC, or any "slick" mating flange, we recommend that you install a metal serrated gasket between the two flanges to assist in the seal.

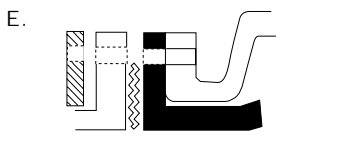

E. When bolting a pinch valve to a PVC or synthetic mating flange, use a split back-up retaining ring, since the mating flange will yield prior to generating enough force on the flange faces for a proper seal.

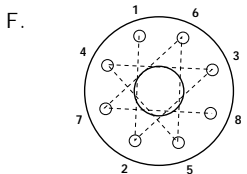

F. Torque all the flange bolts in a star pattern, first to 50% of tabulated valves, then retorque to 100% of tabulated valves. If greater torque is required, continue retorquing in increments of 50% of tabulated valves. Use of high quality anti-seize compound on all bolt threads is recommended.

Variables such as the surface finish on bolt threads, type of anti-seize compound used, and surface finish of the mating flanges all have an effect on the minium torque required to obtain a leak-tight flange seal.

RED VALVE WARRANTY

WARRANTIES - REMEDIES - DISCLAIMERS - LIMITATION OF LIABILITY
Unless otherwise agreed to in writing signed by Red Valve, all Products supplied by Red Valve will be described in the specifications set forth on the face hereof.

THE WARRANTIES SET FORTH IN THIS PROVISION ARE EXCLUSIVE AND IN LIEU OF ALL OTHER WARRANTIES WHETHER STATUTORY, EXPRESS OR IMPLIED (INCLUDING ALL WARRANTIES OF MERCHANTABILITY AND FITNESS FOR A PARTICULAR PURPOSE AND ALL WARRANTIES ARISING FROM COURSE OF DEALING OR USAGE OR TRADE).

Red Valve Products are guaranteed for a period of one year from date of shipment, against defective workmanship and material only, when properly installed, operated and serviced in accordance with Red Valve's recommendations. Replacement for items of Red Valve's manufacture will be made free of charge if proved to be defective within such year; but not claim for transportation, labor or consequential damages shall be allowed. We shall have the option of requiring the return of the defective product to our factory, with transportation charges prepaid, to establish the claim and our liability shall be limited to the repair or replacement of the defective product, F.O.B. our factory. Red Valve will not assume costs incurred to remove or install defective products nor shall we incur backcharges or liquidated damages as a result of warranty work. Red Valve does not guarantee resistance to corrosion erosion, abrasion or other sources of failure, nor does Red Valve guarantee a minimum length of service, or that the product shall be fit for any particular service. Failure of purchaser to give prompt written notice of any alleged defect under this guarantee forthwith upon its discovery, or use, and possession thereof after an attempt has been made and completed to remedy defects therein, or failure to return product or part for replacement as herein provided, or failure to install and operate said products and parts according to instructions furnished by Red Valve, or failure to pay entire contract price when due, shall be a waiver by purchaser of all rights under these representations. All orders accepted shall be deemed accepted subject to this warranty which shall be exclusive of any other or previous warranty, and shall be the only effective guarantee or warranty binding on Red Valve, anything on the contrary contained in purchaser's order, or represented by any agent or employee of Red Valve in writing or otherwise, notwithstanding implied warranties. RED VALVE MAKES NO WARRANTY THAT THE PRODUCTS, AUXILIARIES AND PARTS ARE MERCHANTABILITY OR FIT FOR ANY PARTICULAR PURPOSE.